



Proudly Manufactured in the USA

AquFlow

Metering Pumps & Systems

The Legendary Brand in Metering Pumps

Offering the widest range of material selection as well as flow rates up to 1,750 GPH (Simplex), 3,500 GPH (Duplex)

Complies with API 675 Standards



COMPANY PROFILE

Originally founded in 1972 as Hydroflo to manufacture premium chemical metering pumps, this company was acquired by Precision Flow in 2007 and relaunched as Aquflow. With continued development and refinement, we currently have the most extensive range of flow capacities, pressure and corrosion resistant materials of construction under one brand. Over the last 40 years we have gained a well-deserved reputation for making high quality pumps that outlast and outperform most competitive models.



The pumps are made in a state of the art facility in Irvine, California, USA. The manufacturing process we have in place emphasizes flexibility and agility to accommodate market requirements rapidly. Hence our fast deliveries delight customers who may have their process down for the lack of a pump. Aquflow test and qualification process ensures that our pumps comply with the highest standards of the industry such as API 675. Our location near major ports help us ship the products expeditiously and cost effectively throughout the world.

HISTORY TIMELINE

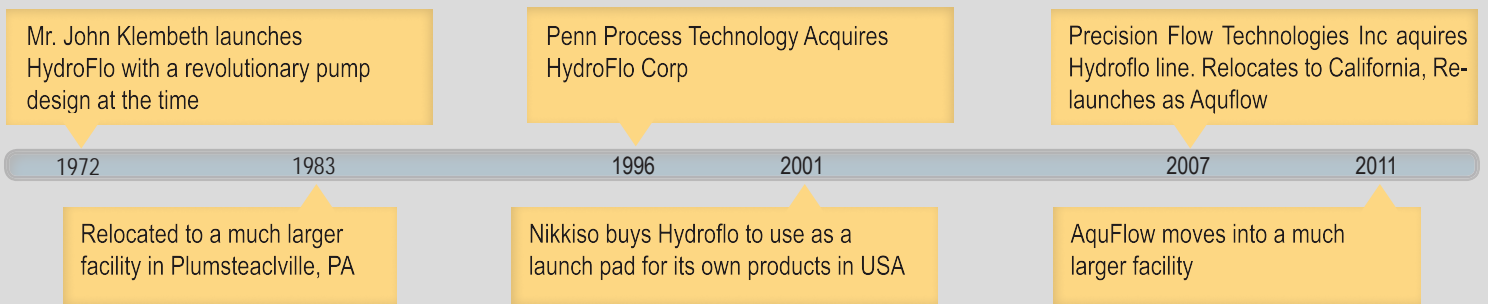

WHO WE ARE	HOW IT BENEFITS OUR CUSTOMERS
USA based midsized manufacturer	Expect us to be lean, agile and flexible to survive
Privately owned company	We answer to our customers, not shareholders
Industry veterans with a passion for pumps	We take personal pride in every pump we build
40 years of handling the most difficult chemicals	We have ready solutions for most problems
WHAT WE MAKE	HOW IT BENEFITS OUR CUSTOMERS
Extensive range of hydraulic diaphragm pumps	All dosing pump sizes and pressures in one place
Efficiently designed hydraulic oil channels	Quick start up, no air locking, accurate & dependable
Robust, durable design perfected over 4 decades	Pumps that run for decades with minimal maintenance
Ability to adjust flow while pump is running	Overall ease and simplicity of installation and operation
All replaceable and service parts located intuitively	Quick & easy to maintain and service

API - 675

This standard is written by the American Petroleum Institute for controlled volume (metering/dosing) pumps. It requires the hydraulically balanced diaphragm pumps to meet certain minimum requirements for life, uninterrupted operation, servicability, accuracy and repeatability among other things. All AquFlow hydraulic diaphragm pumps comply with these standards. Documentation and test reports in accordance with the standards can be furnished for an additional charge when requested in advance.

AQUFLOW PUMP CUTAWAY

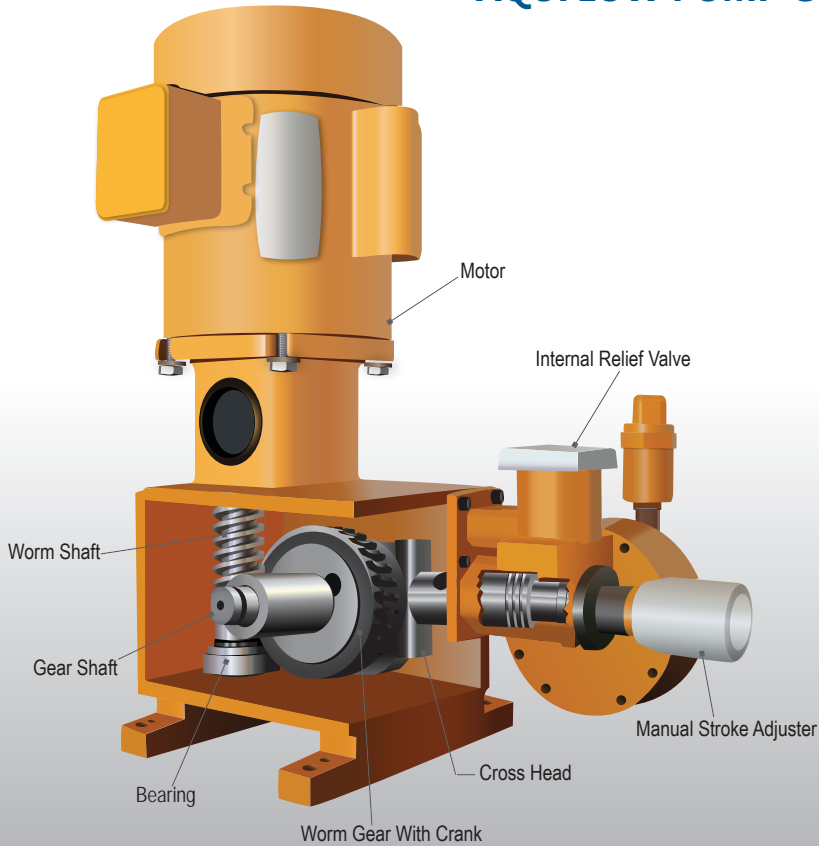

GENERIC LIQUID END CROSS SECTION

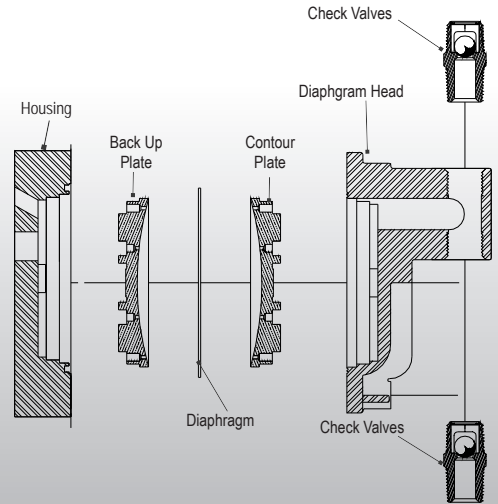

HYDRAULICALLY BALANCED DIAPHRAGM - MORE ACCURATE, LONGER LASTING, MINIMUM MAINTENANCE

There are several metering pump designs that are available today. A hydraulic diaphragm is the most evolved version which offers several advantages over other types. Following are some points to consider while choosing between different types based on your application.

Piston Plunger

- Metallic piston in contact with process fluid
- Piston/Plunger packing exposed to process fluid
- Contamination with grease/lubricant

Solenoid Diaphragm

- Unbalanced diaphragm stem failure
- Works only for light duty low pressure applications
- Low durability design

Hydraulic Balanced Diaphragm

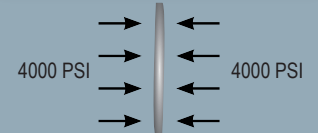

UnBalanced Diaphragm



Mechanical Diaphragm

- Unbalanced diaphragm - frequent replacements
- Not suitable for high pressure
- Less accurate due to rolling diaphragm

Other Hydraulic Diaphragm Advantages

- Run by hydraulic oil which is non compressible
- Balanced pressure on both sides to increase life
- Virtually maintenance free for years
- Built in safety features - Internal relief valve

FLOW CAPACITY RANGE - FROM VERY LOW TO VERY HIGH

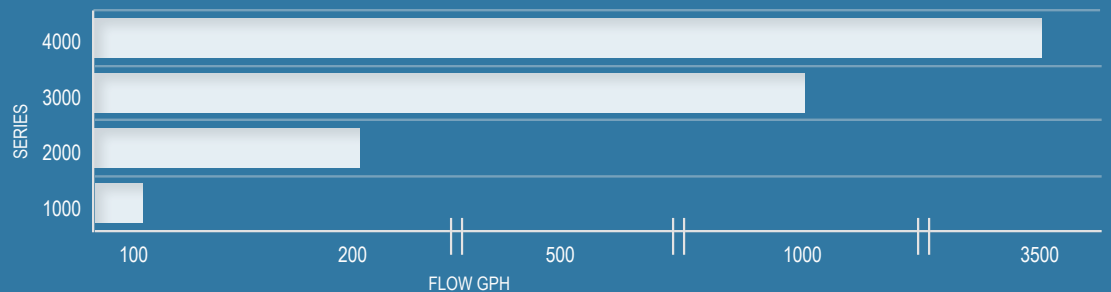
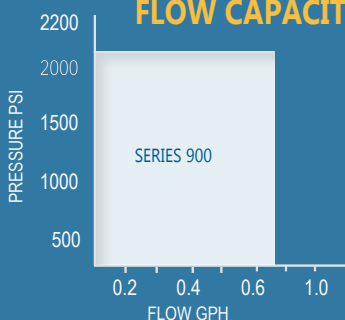

AquFlow Ultra - Low Capacity Pumps

MARKETS & APPLICATIONS



Water & Wastewater Treatment

AquFlow water treatment pumps are engineered for injecting disinfectant chemicals, acids, polymers, and other agents used in water treatment facilities. Wastewater treatment pumps are used for injecting chemicals for the removal of caustic and cyanide, pH control, and more.

TYPICAL APPLICATIONS (WATER)

- Sodium hypochlorite and Calcium hypochlorite for disinfection
- Sulfuric acid and sodium silicate
- Alum or sodium aluminate as a coagulant agent
- Slurries for filtration
- Phosphate for red water control
- Lime slurries in softening and pH control
- Potassium permanganate for manganese and iron removal
- Polymers for primary coagulation
- Metering activated carbon slurries for taste and odor control

TYPICAL APPLICATIONS (WASTEWATER)

- Sodium hypochlorite for disinfection
- Lime slurries for pH control (corrosion control) and coagulation
- Ferric chloride and alum injection for coagulation
- Copper sulfate injection for algae control
- Activated carbon or diatomaceous earth slurries for odor and color control
- Caustic soda (NaOH) for metal removal, pH control, and cyanide removal
- Anionic and cationic polymer injection for phosphate removal, coagulation and filtration



Agriculture

Used for agricultural fertigation and chemigation, AquFlow agriculture pumps inject fertilizers and other chemicals into agricultural irrigation pipelines.

TYPICAL APPLICATIONS

- Fertigation - injecting fertilizers and other chemicals in the irrigation water pipelines.
- Chemigation - Injecting pesticides and insecticides to protect crops
- Acid Pumping for pH adjustment
- Chlorine Pumping for disinfecting water

Oil & Gas

AquFlow oil and gas industry pump systems are specially engineered to handle industrial oil and gas requirements for injecting corrosion inhibitors, pH adjustment agents for corrosion control, chemical desalting of crude oil, introducing lubricants for gas lines, etc.

TYPICAL APPLICATIONS

- Injecting Corrosion Inhibitors
- Pumping chemicals to adjust pH of sour gas or crude oil to reduce corrosion
- Injecting sludge inhibitors for fuel oils
- Pumping additives for bacteria control of water for well flooding
- Caustic soda to crude oils or soured gasoline for rerun through cracking stills
- Sampling feed stock, jet fuels, gasolines, and intermediates for analysis



Chemical Processing

Used in a wide variety of chemical processing pump applications, AquFlow chemical processing pumps are commonly used to introduce aromatics, ethanolamines, ethylene glycols, and other chemicals required in industrial manufacturing and processing environments.

TYPICAL CHEMICALS

- Ethers, Aromatics (Toluene, Paraxylene, Benzene, and Orthoxylene)
- Ethylene Glycols for manufacturing plastics, textiles, latex paints, adhesives, etc.
- Propylene Oxide, Vinyl Monomers, Deionized water, Methanol, Sodium Tetraborate (Borax) solutions, Tetrahydrofuran, Alumina catalyst solutions

Food Processing

Food grade pumps that are used in food and beverage manufacturing plants for pumping compounds, ingredients, candy coating and flavors

TYPICAL APPLICATIONS (BREWERIES, DISTILLERIES)

- Water Conditioning for the product
- Metering acid during mashing for pH control of brewing water
- Handling filter aids (diatomaceous earth)
- Aging chemicals dispensing
- Froth inhibitor at bottle filling machine
- Pumping Sulfuric Acid

TYPICAL APPLICATIONS (FOOD & DAIRY)

- Mixing ingredients in manufacture of mustard, mayonnaise and salad dressings
- Coatings and flavoring to dry cereals
- Oil addition to peanuts
- Adding preservatives
- Addition of flavoring oils to flour, cake, and pie mixes
- Metering vitamins to many food products, including milk
- Metering ingredients and vitamins to both pet and cattle feed stock
- Pumping hormones to animal feed



Paints & Dyes

AquFlow pumps can be used for water and solvent-based paints, ink, varnish, glue, adhesives and solvents.

TYPICAL APPLICATIONS

- Addition of measured quantities of pigments
- Automatic filling of containers
- Metering inks and various pigments for printing
- Mixing ingredients for inks

Pulp & Paper

Pulp & Paper industry pumps for addition of sulfuric acid or alum for pH control, adding colorants, kolin slurries, titanium dioxide, etc.

TYPICAL APPLICATIONS

- Addition of sulfuric acid or alum for pH control of pulp
- Adding colorants
- Metering coagulants
- Adding kaolin slurries as paper filler
- Introducing titanium dioxide to pulp for opacity control in thin papers

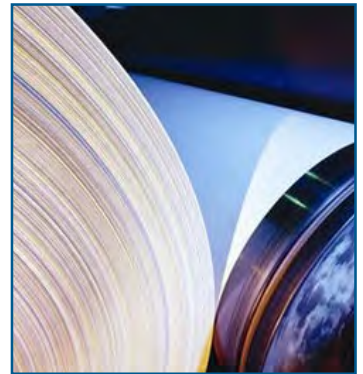

Miscellaneous

Other pumps can be used in applications such as mining, fireproofing, chemical spraying, boiler feed applications, car washes, laundry facilities, and more.

TYPICAL APPLICATIONS (MINING)

- Additives to pH adjustment of the ore
- Handling liquified metals
- Dust control spraying
- Metering depressing agents
- Pumping caustic soda (sodium hydroxide) for neutralizing
- Metering various leaching chemicals – solvent extraction
- Flotation control

SERIES 1000 PERFORMANCE TABLE



Features

- Flow capacities up to 123 GPH (Duplex)
- Pressure Up to 4,000 PSI
- Unibody Design – Less Parts
- Metering accuracy +/- 1%
- Easy capacity controls – Manual/Auto
- Built in safety – Internal relief valve
- Available in duplex to double flow capacity
- Ability to handle difficult liquids like slurries, off-gassing, and high viscosity liquids

Specifications

Flow capacity adjustment: 0-100%
While the pump is running or stopped

Turndown Ratio

Stroke length – 10:1
Stroke frequency – 10:1
Combined – 100:1

Metering accuracy

Steady state: +/- 1%
Linearity: +/- 1%
Combined: +/- 1%

Maximum process fluid temperature

Custom engineered metallic liquid end: 500°F
Metallic liquid end/PTFE diaphragm: 250°F(121°C)
Plastic Head: 140°F (60°C)

Hydraulic Oil

Oil capacity: 2 qt. (simplex)
3 qt. (Duplex)

Plunger Stroke

Stroke length: 3/4"

Displacement per stroke – by plunger size

3/8" - 0.0857 cu. in. (1.353 ml)
9/16" - 0.18595 cu. in. (3.047 ml)
3/4" - 0.33073 cu. in. (5.419 ml)
7/8" - 0.450246 cu. in. (7.378ml)
1-1/8" - 0.78649 cu. in. (12.888 ml)
1-5/8" - 1.5537 in (25.461 ml)

Liquid End Material Options

316 SS, Alloy 20, Hastelloy C,
PVC, PVDF and PTFE

AquFlow Model Number	Capacity GPH (LPH)	Pressure PSIG (bars)	Speed (SPM)	Plunger Diameter	Connection (Metallic - NPT)
CA4T 3829-0X013	0.55 (2.1)	4,000 (275)	29	3/8"	1/4"
CA4T 3858-0X013	1.10 (4.2)		58		
CA4T 3897-0X013	1.85 (7.0)		97		
CA4T 3812-0X013	2.25 (8.5)		117		
CA4T 3814-0X013	2.70 (10.2)		140		
CA4T 3817-0X013	3.28 (12.4)		170		
CJ4T 5629-0X014	1.25 (4.7)	2,000 (75)	29	9/16"	3/8"
CJ4T 5658-0X014	2.50 (9.5)		58		
CJ4T 5697-0X014	4.20 (15.9)		97		
CJ4T 5612-0X014	5.10 (19.3)		117		
CJ4T 5614-0X014	6.09 (23.1)		140		
CJ4T 5617-0X014	7.40 (28.0)		170		
CJ4T 7529-0X014	2.25 (8.5)	1,100 (75)	29	3/4"	3/8"
CJ4T 7558-0X014	4.50 (17.1)		58		
CJ4T 7597-0X014	7.50 (28.4)		97		
CJ4T 7512-0X014	9.05 (34.3)		117		
CJ4T 7514-0X014	10.8 (40.9)		140		
CJ4T 7517-0X014	13.1 (49.6)		7		
CJ4T 8729-0X014	3.05 (11.5)	700 (48)	29	7/8"	3/8"
CJ4T 8758-0X014	6.10 (23.0)		58		
CJ4T 8797-0X014	10.2 (38.6)		97		
CJ4T 8712-0X014	12.5 (47.3)		117		
CJ4T 8714-0X014	14.7 (55.6)		140		
CJ4T 8717-0X014	17.9 (67.8)		170		
CJ4T 11329-0X014	5.33 (20.2)	400 (48)	29	1-1/8"	3/8"
CJ4T 11358-0X014	10.6 (40.1)		58		
CJ4T 11397-0X014	17.8 (67.4)		97		
CJ4T 11312-0X014	22 (83.3)		117		
CJ4T 11314-0X014	25.7 (97.3)		140		
CJ4T 11317-0X014	31.1 (117.7)		170		
CJ4T 16229-0X018	10.5 (39.7)	200 (13)	29	1-5/8"	1/2"
CJ4T 16258-0X018	21.0 (79.5)		58		
CJ4T 16297-0X018	35.3 (133.6)		97		
CJ4T 16212-0X018	42.5 (160.9)		117		
CJ4T 16214-0X018	50.9 (192.3)		140		
CJ4T 16217-0X018	61.8 (233.5)		170		

X = 4 for 316 SS, 5 for ALLOY 20, 6 for HAST. C, 8 for PVC, A for PVDF

PERFORMANCE CURVE - TYPICAL

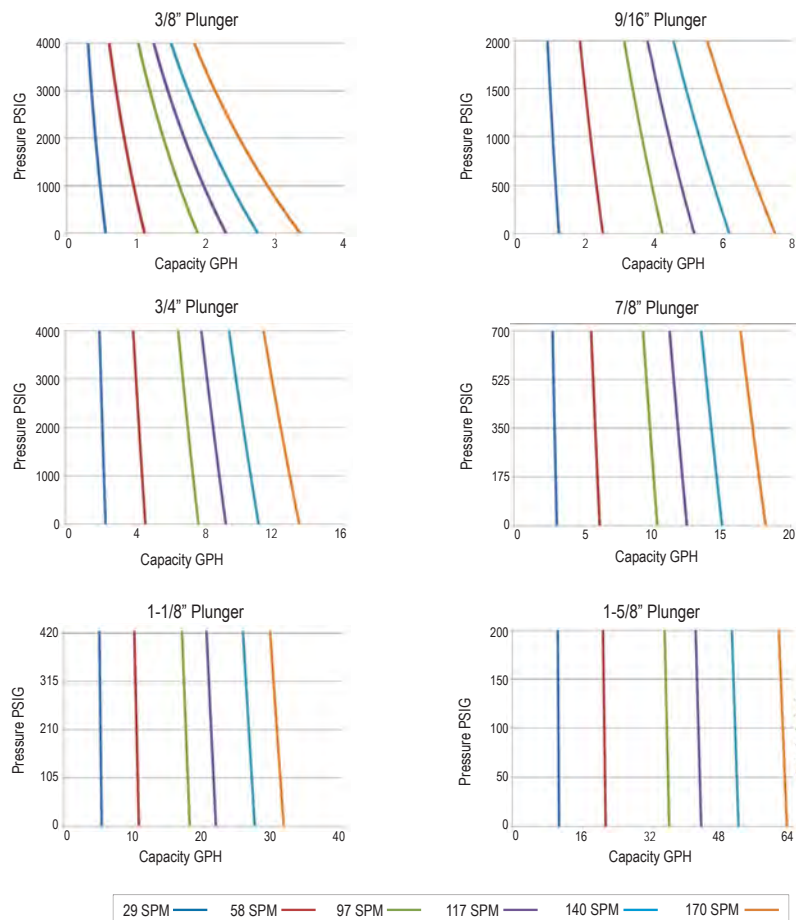

CROSS SECTION

Standard Model

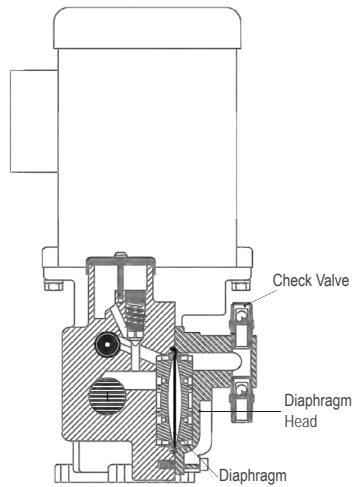
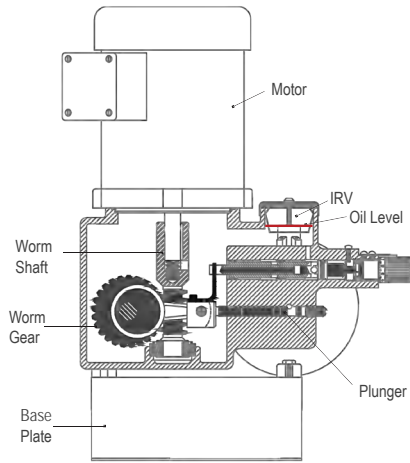

Liquid End (Metallic)

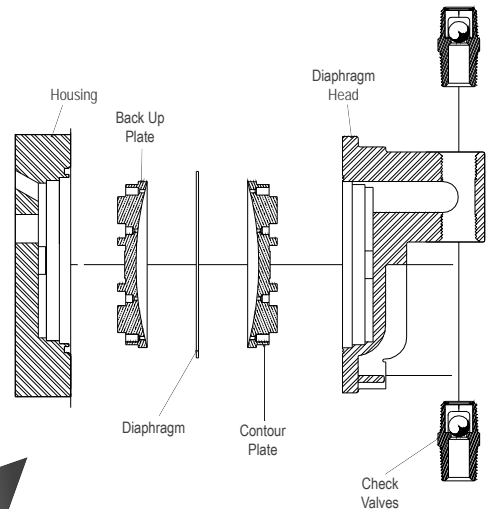

DIMENSIONS

(Shown: Typical Series 1000 Model with Metallic Liquid End and 3/8" NPTM Discharge/Suction Connections)

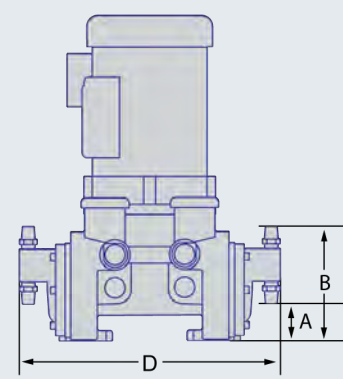
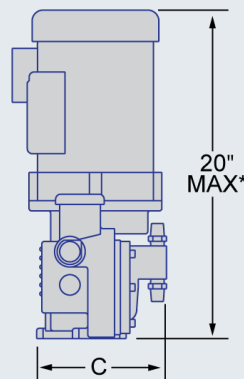
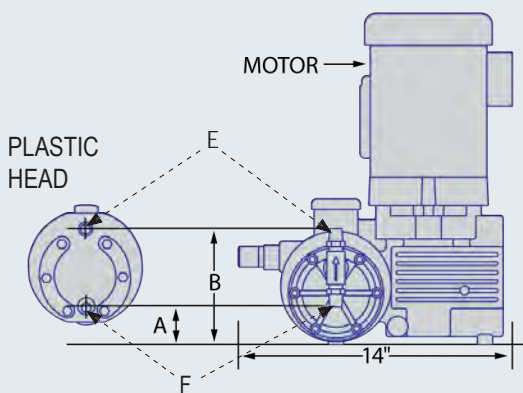

Series 1000, Duplex

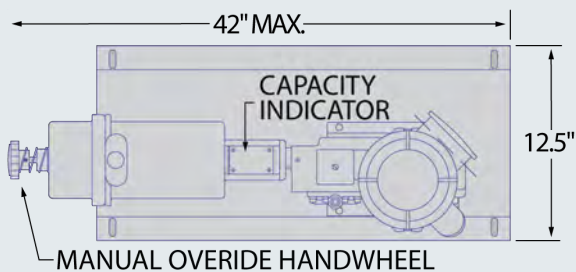

Series 1000 with ECCA

	A	B	C	D	E (NPT)	F (NPT)
Metallic	1-3/4"	5-1/2"	6-1/3"	13"	3/8" M	3/8" M
Plastic**	1"	4-3/4"	7"	14"	3/4" F	1/2" F
Plastic on 3-1/4" Base	4-1/4"	8"	7"	--	3/4" F	1/2" F

*Standard motor. Subject to change depending on motor specs.

**Plastic liquid end material pump always supplied w/ base.

***Standard weight is 70 lbs. Varies depending on material and configuration.



Features

- Flow capacities up to 180 GPH (Duplex)
- Pressure Up to 1,800 PSI
- Modular design in aluminum housing
- Metering accuracy +/- 1%
- Easy capacity controls – Manual/Auto
- Built in safety – Internal relief valve
- Available in duplex to double flow capacity
- Ability to handle difficult liquids like slurries, off-gassing, and high viscosity liquids

Specifications

Flow capacity adjustment: 0-100%
While the pump is running or stopped

Turndown Ratio

Stroke length – 20:1
Stroke frequency – 20:1
Combined – 200:1

Metering accuracy

Steady state: +/- 1 %
Linearity: +/- 1 %
Combined: +/- 1 %

Maximum process fluid temperature

Custom engineered metallic liquid end: 500°F (260°C)
Metallic liquid end/PTFE diaphragm: 250°F(121°C)
Plastic Head: 140°F (60°C)

Hydraulic Oil

Oil capacity:
4 qt. (Simplex & Duplex)

Plunger Stroke

Stroke length: 1-1/2"

Displacement per stroke – by plunger size

3/4" - 0.6976 cu. in. (11.43 ml)
1" - 1.1334 cu. in. (18.57 ml)
1-1/4" - 1.8757 cu. in. (30.77 ml)
1-1/2" - 2.0797 cu. in. (34.08 ml)

Liquid End Material Options

316 SS, Alloy 20, Hastelloy C,
PVC, PVDF and PTFE

AquFlow Model Number	Capacity GPH (LPH)	Pressure PSIG (bars)	Speed (SPM)	Plunger Diameter	Connection (Metallic - NPT)
CD3T 0529-0X014	3.98 (10.6)	1,800 (124)	29	5/8"	3/8"
CD3T 0558-0X014	7.97 (21.2)		58		
CD3T 0597-0X014	13.3 (36.0)		97		
CD3T 0512-0X014	16.07 (43.2)		117		
CD3T 0514-0X014	19.2 (51.9)		140		
CD3T 0519-0X014	26.2 (70.8)		191		
CD3T 0629-0X014	4.7 (17.8)	1,000 (69)	29	3/4"	3/8"
CD3T 0658-0X014	9.4 (35.6)		58		
CD3T 0697-0X014	15.7 (59.8)		97		
CD3T 0612-0X014	19.0 (71.9)		117		
CD3T 0614-0X014	22.7 (85.6)		140		
CD3T 0619-0X014	30.99 (117.3)		191		
CD3T 0829-0X014	7.68 (28.8)	360 (25)	29	1"	1/2"
CD3T 0858-0X014	15.37 (57.5)		58		
CD3T 0897-0X014	25.7 (96.1)		97		
CD3T 0812-0X014	31.0 (115.8)		117		
CD3T 0814-0X014	37.09 (138.9)		140		
CD3T 0819-0X014	50.61 (189.3)		191		
CD3T 1029-0X014	12.67 (45.4)	210 (14)	29	1-1/4"	3/8" M
CD3T 1058-0X014	25.35 (90.8)		58		
CD3T 1097-0X018	42.39 (151.4)		97		
CD3T 1012-0X018	51.13 (185.5)		117		1/2" F
CD3T 1014-0X018	61.18 (227.1)		140		
CD3T 1019-0X018	83.47 (302.8)		191		
CD3T 1229-0X014	16.0 (53.0)	195 (13)	29	1-1/2"	3/8" M
CD3T 1258-0X015	32.07 (106.0)		58		
CD3T 1297-0X018	53.63 (177.9)		97		
CD3T 1212-0X018	64.68 (212.0)		117		1/2" F
CD3T 1214-0X018	77.4 (253.6)		140		
CD3T 1219-0X018	105.6 (340.6)		191		

X = 4 for 316 SS, 5 for ALLOY 20, 6 for HAST. C, 8 for PVC, A for PVDF

PERFORMANCE CURVE - TYPICAL

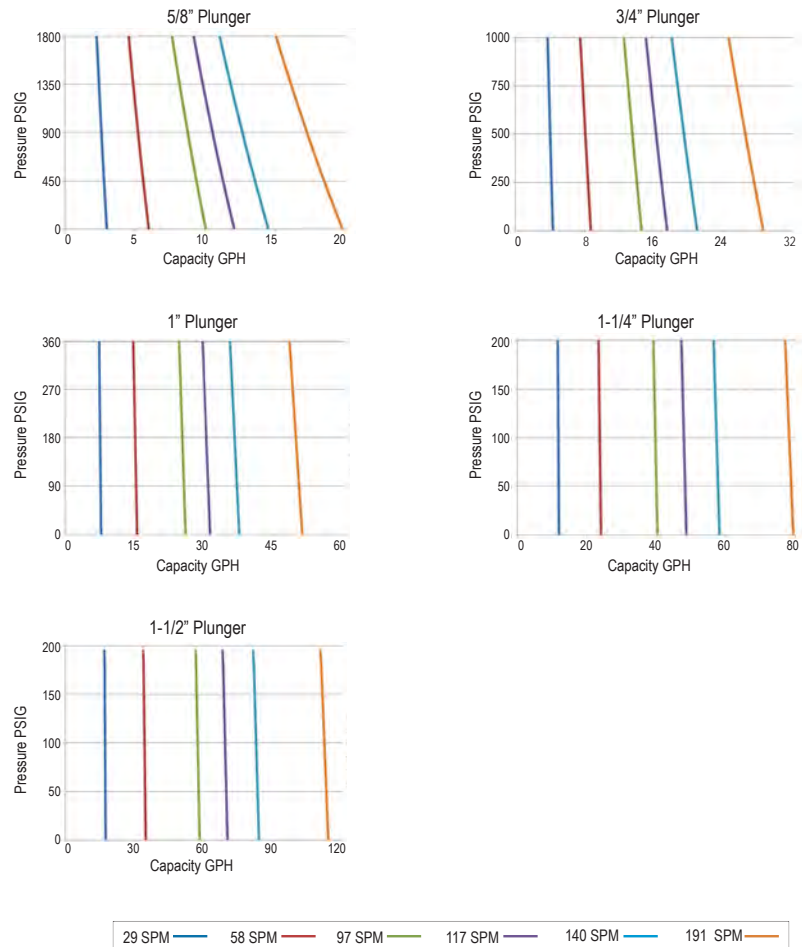

CROSS SECTION

Standard Model

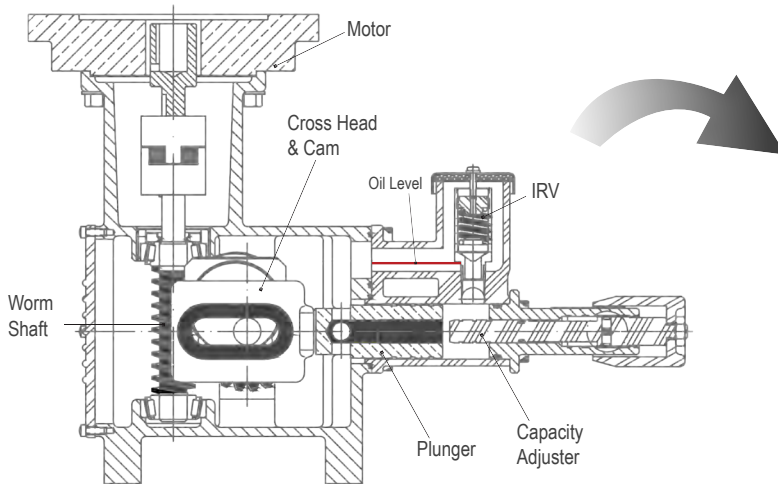

Liquid End (Metallic)

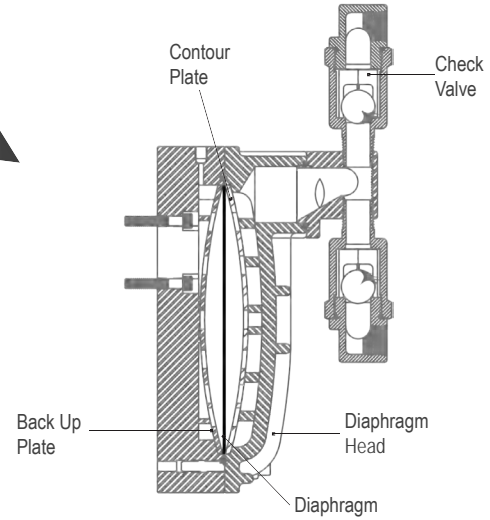

DIMENSIONS

(Shown: Typical Series 2000 Model with Metallic Liquid End and 1/2" NPTF Discharge/Suction Connections)

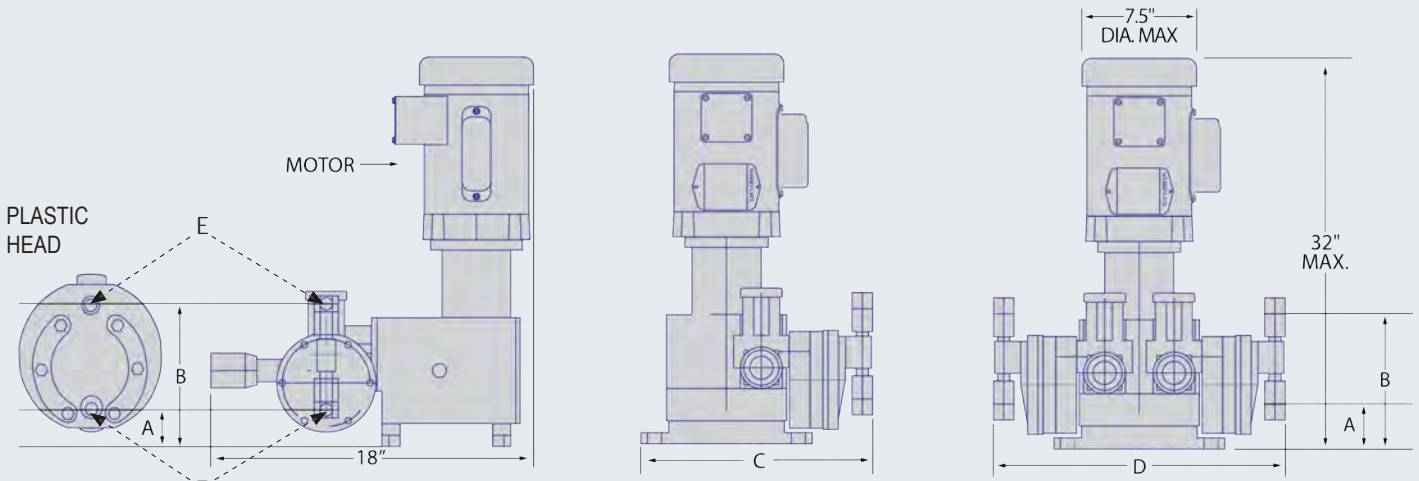

Series 2000, Duplex

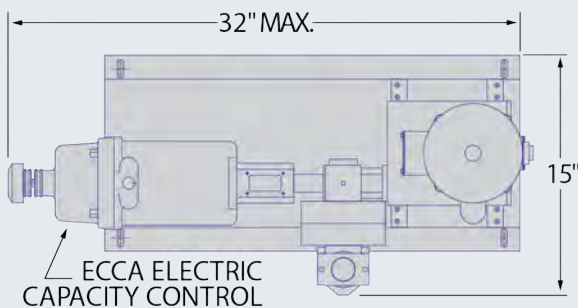

Series 2000 with ECCA

	A	B	C	D	E (NPT)	F (NPT)
Metallic	2"	7-3/4"	14"	15-3/4"	1/2" M	1/2" M
Plastic	2"	6-5/8"	13"	17"	3/4" F	1" F

*Standard weight is 85 lbs. Varies depending on material and configuration.



Features

- Flow capacities up to 920 GPH (Duplex)
- Pressure Up to 700 PSIG
- Modular design in aluminum housing
- Metering accuracy +/- 1%
- Easy capacity controls – Manual/Auto
- Built in safety – Internal relief valve
- Available in duplex to double flow capacity
- Ability to handle difficult liquids like slurries, off-gassing, and high viscosity liquids

Specifications

Flow capacity adjustment: 0-100%
While the pump is running or stopped

Turndown Ratio **Metering accuracy**
Stroke length – 36:1 Steady state: +/- 1 %
Stroke frequency – 36:1 Linearity: +/- 1 %
Combined – 360:1 Combined: +/- 1 %

Maximum process fluid temperature

Custom engineered metallic liquid end: 500°F
Metallic liquid end/PTFE diaphragm: 250°F(121°C)
Plastic Head: 140°F (60°C)

Hydraulic Oil **Plunger Stroke**
Oil capacity: 12 qt. Stroke length: 3"

Displacement per stroke – by plunger size

- 1" - 2.3569 cu. in. (38.46 ml)
- 1-1/4" - 3.6738 cu. in. (60.20 ml)
- 1-1/2" - 5.2906 cu. in. (86.70 ml)
- 1-3/4" - 7.2063 cu. in. (118.09 ml)
- 2" - 9.4102 cu. in. (154.21 ml)
- 2-1/4" - 11.9023 cu. in. (195.04 ml)
- 2-1/2" - 14.1561 cu. in. (231.98 ml)

Liquid End Material Options

316 SS, Alloy 20, Hastelloy C, PVC, PVDF and PTFE

AquFlow Model Number	Capacity GPH (LPH)	Pressure PSIG (bars)	Speed (SPM)	Plunger Diameter	Connection (Metallic - NPT)
CNIT 0829-0X018	24.1 (60.2)	700 (48)	44	1"	1/2"
CNIT 0858-0X018	31.9 (120.7)		58		
CNIT 0888-0X018	48.0 (181.7)		88		
CNIT 0812-0X018	64.0 (242.3)		117		
CNIT 0814-0X018	76.0 (287.7)		140		
CNIT 1029-0X018	37.8 (94.6)	405 (28)	44	1-1/4"	1/2"
CNIT 1058-0X018	50.0 (189.3)		58		
CNIT 1088-0X018	75.7 (286.5)		88		
CNIT 1012-0X018	100.0 (378.5)		117		
CNIT 1014-0X018	120.0 (454.2)		140		
CNIT 1229-0X018	54.4 (135.9)	265 (18)	44	1-1/2"	1/2"
CNIT 1258-0X018	71.8 (271.8)		58		
CNIT 1288-0X018	109.0 (412.6)		88		
CNIT 1212-0X018	145.0 (548.9)		117		
CNIT 1214-0X01A	173.0 (654.9)		140		
CNIT 1429-0X018	74.0 (185.1)	180 (12)	44	1-3/4"	1/2"
CNIT 1458-0X018	97.8 (370.2)		58		
CNIT 1488-0X018	148.0 (560.2)		88		
CNIT 1412-0X01A	197.0 (745.7)		117		
CNIT 1414-0X01A	236.0 (893.4)		140		
CNIT 1629-0X018	96.8 (241.9)	130 (9)	44	2"	1-1/2"
CNIT 1658-0X018	128.0 (484.5)		58		
CNIT 1688-0X01A	194.0 (724.4)		88		
CNIT 1612-0X01B	258.0 (976.6)		117		
CNIT 1614-0X01B	308.0 (1,165.9)		140		
CNIT 1829-0X018	122.4 (305.9)	95 (6)	44	2-1/4"	1/2"
CNIT 1858-0X018	161.0 (609.5)		58		
CNIT 1888-0X01A	245.0 (927.4)		88		
CNIT 1812-0X01B	326.0 (1,234.0)		117		
CNIT 1814-0X01C	389.0 (1,476.3)		140		
CNIT 2029-0X018	145.0 (378.5)	75 (5)	44	2-1/2"	1-1/2"
CNIT 2058-0X01A	191.0 (757.1)		58		
CNIT 2088-0X01B	291.0 (1,135.6)		88		
CNIT 2012-0X01C	387.0 (1,514.2)		117		
CNIT 2014-0X01C	463.0 (1,824.6)		140		

X = 4 for 316 SS, 5 for ALLOY 20, 6 for HAST. C, 8 for PVC, A for PVDF

PERFORMANCE CURVE - TYPICAL

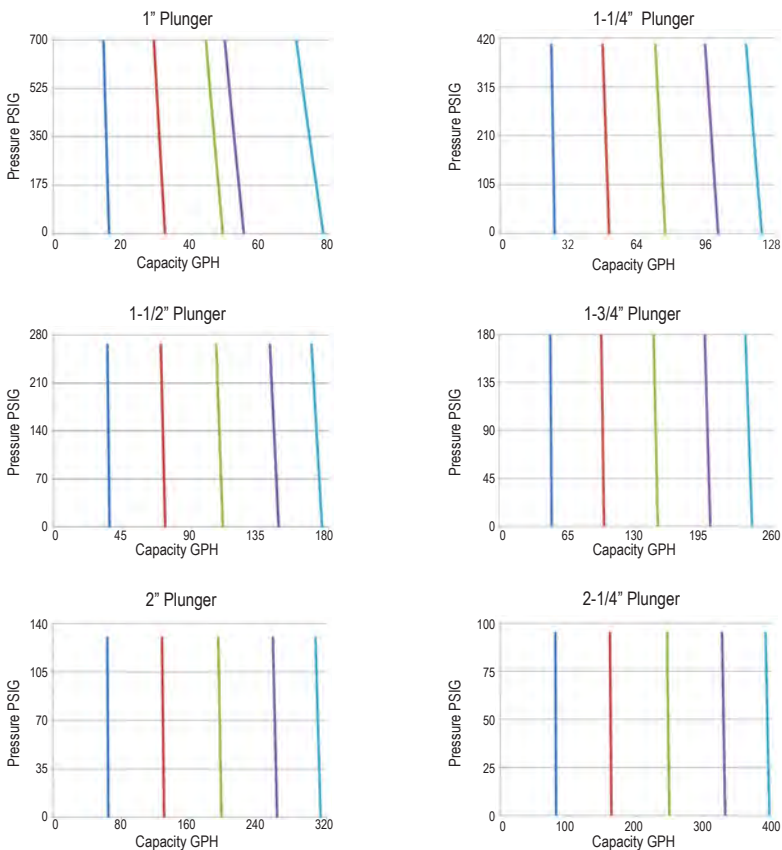

29 SPM — 58 SPM — 97 SPM — 117 SPM — 140 SPM

Continued on next page

CROSS SECTION

Standard Model

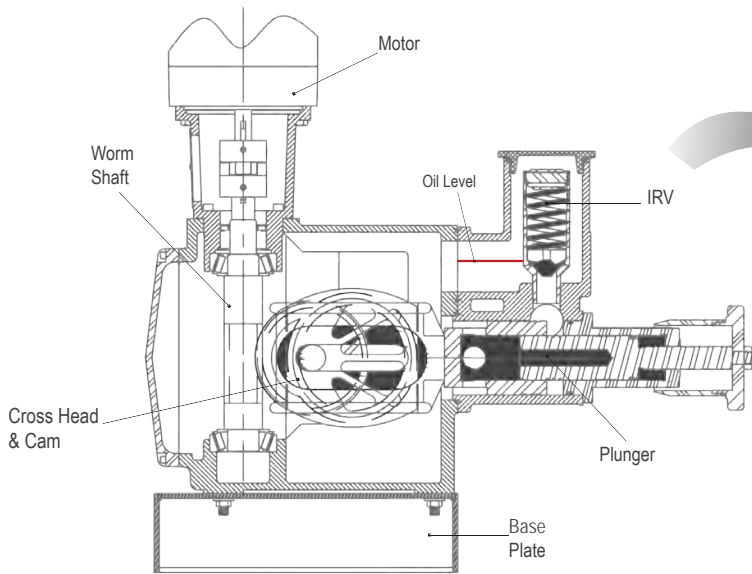

Liquid End (Metallic)

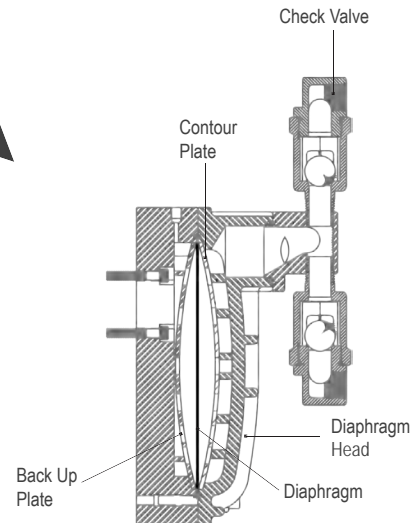

DIMENSIONS

(Shown: Typical Series 3000 Model with Metallic Liquid End and 1-1/2" NPTM Discharge/Suction Connections)

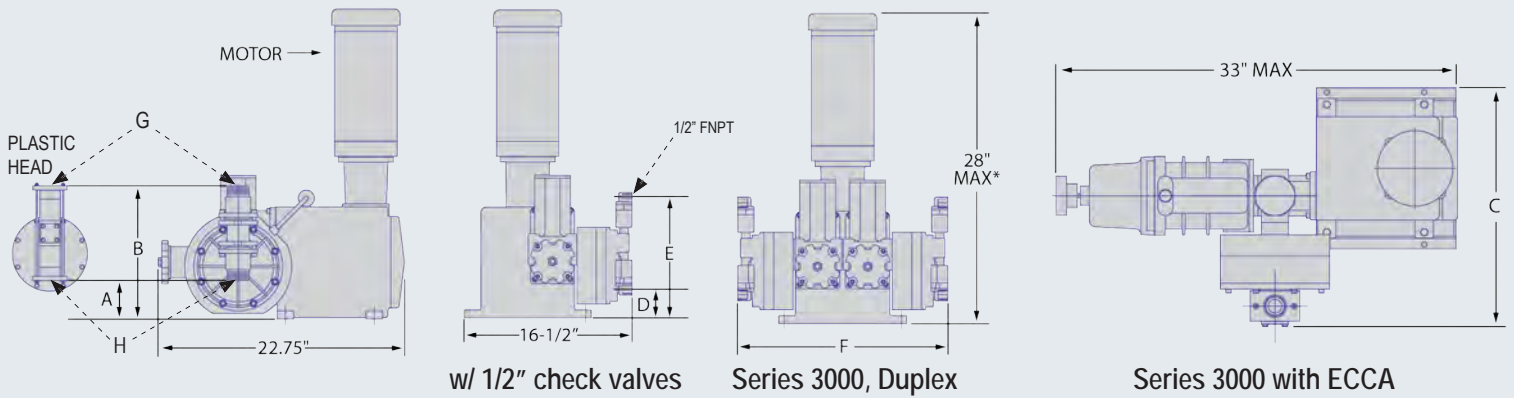

Continued from page 10

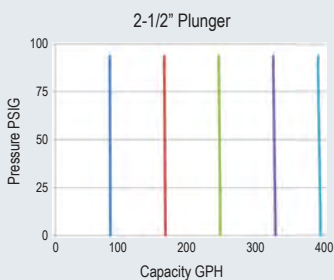

	A	B	C	D	E	F	G (NPT)	H (NPT)
Metallic	4-1/6"	12"	20-3/8"	3-3/4"	12"	23-3/16"	1-1/2" M	1-1/2" M
Plastic	4-5/8"	15-7/8"	18-5/8"	--	--	24"	1-1/4" F	1-1/4" F

*Standard motor. Subject to change depending on motor specs.

**Standard weight is 250 lbs. Varies depending on material and configuration.



Features

- Flow capacities up to 3530 GPH (Duplex)
- Pressure Up to 3,500 PSI
- Modular design in aluminum housing
- Metering accuracy +/- 1%
- Easy capacity controls – Manual/Auto
- Built in safety – Internal relief valve
- Available in duplex to double flow capacity
- Ability to handle difficult liquids like slurries, off-gassing, and high viscosity liquids

Specifications

Flow capacity adjustment: 0-100%
While the pump is running or stopped

Turndown Ratio **Metering accuracy**
Stroke length – 48:1 Steady state: +/- 1 %
Stroke frequency – 48:1 Linearity: +/- 1%
Combined – 480:1 Combined: +/- 1%

Maximum process fluid temperature
Custom engineered metallic liquid end: 500°F
Metallic liquid end/PTFE diaphragm: 250°F (121°C)
Plastic Head: 140°F (60°C)

Hydraulic Oil **Plunger Stroke**
Oil capacity: 52 qt. Stroke length: 4"

Displacement per stroke – by plunger size
7/8" - 2.2698 cu. in. (37.19 ml)
1-1/8" - 3.8013 cu. in. (62.29 ml)
1-9/16" - 7.6453 cu. in. (125.29 ml)
2-1/2" - 19.63 cu. in. (321.77 ml)
3" - 28.1989 cu. in. (462.12 ml)
4" - 50.34 cu. in. (824.99 ml)

Liquid End Material Options
316 SS, Alloy 20, Hastelloy C,
PVC, PVDF and PTFE

AquFlow Model Number	Capacity GPH (LPH)	Pressure PSIG (bars)	Speed (SPM)	Plunger Diameter	Connection (Metallic - NPT)
GNIT 0744-BC01A GNIT 0770-BC01A GNIT 0788-BC01A GNIT 0714-BC01A	22.6 (85.5) 36.0 (136.3) 45.0 (170.3) 72.0 (272.5)	3,500 (241)	44 70 88 40	7/8"	1-1/4"
GNIT 0944-BC01A GNIT 0970-BC01A GNIT 0988-BC01A GNIT 0914-BC01A	38.5 (145.7) 61.5 (232.8) 77.0 (291.5) 123 (465.6)	2,000 (138)	44 70 88 140	1-1/8"	1-1/4"
GNIT 1344-BC01F GNIT 1370-BC01F GNIT 1388-BC01F GNIT 1314-BC01F	79.5 (300.9) 126.0 (477.0) 159.0 (601.9) 253.0 (957.7)	1,000 (69)	44 70 88 140	1-9/16"	2-1/2"
GNIT 2044-BC01F GNIT 2070-BC01F GNIT 2088-BC01F GNIT 2014-BC01F	210.0 (794.9) 335.0 (1,268.1) 421.0 (1,593.7) 671.0 (2,540.0)	370 (26)	44 70 88 140	2-1/2"	2-1/2"
GNIT 2444-BC01H GNIT 2470-BC01H GNIT 2488-BC01H GNIT 2414-BC01H	304.0 (1,150.8) 485.0 (1,835.9) 609.0 (2,305.3) 970.0 (3,671.8)	295 (20)	44 70 88 140	3"	4"
GNIT 3244-BC01H GNIT 3270-BC01H GNIT 3288-BC01H GNIT 3214-BC01H	554.0 (2,097.1) 882.0 (3,338.7) 1,109.0 (4,198.0) 1,765.0 (6,681.2)	160 (11)	44 70 88 140	4"	4"

X = 4 for 316 SS, 5 for ALLOY 20, 6 for HAST. C, 8 for PVC, A for PVDF

PERFORMANCE CURVE - TYPICAL

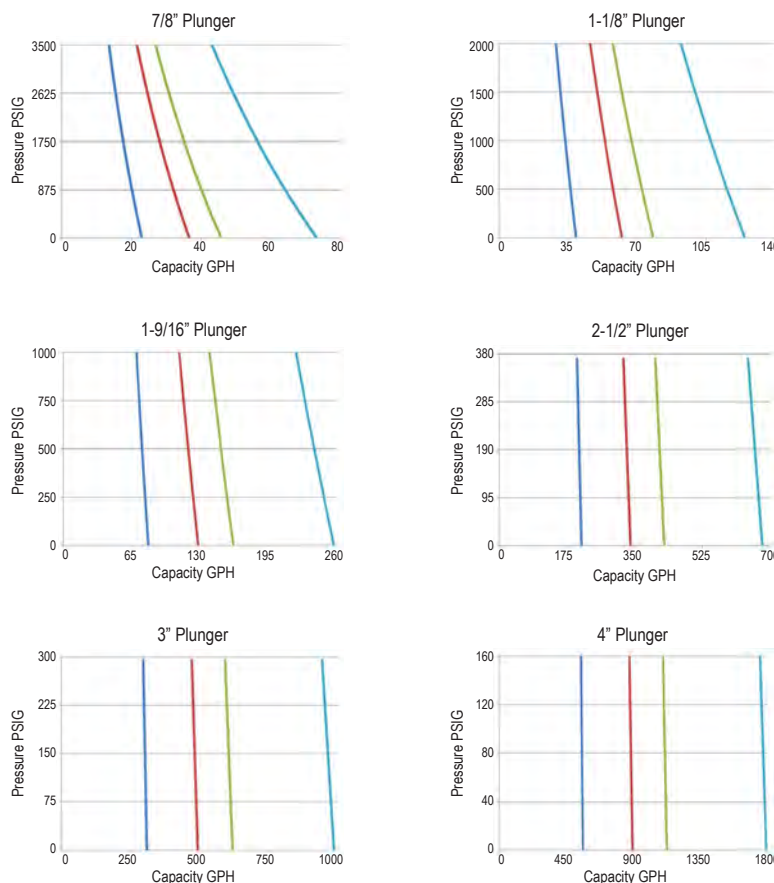

44 SPM — 70 SPM — 88 SPM — 140 SPM —

CROSS SECTION

Standard Model

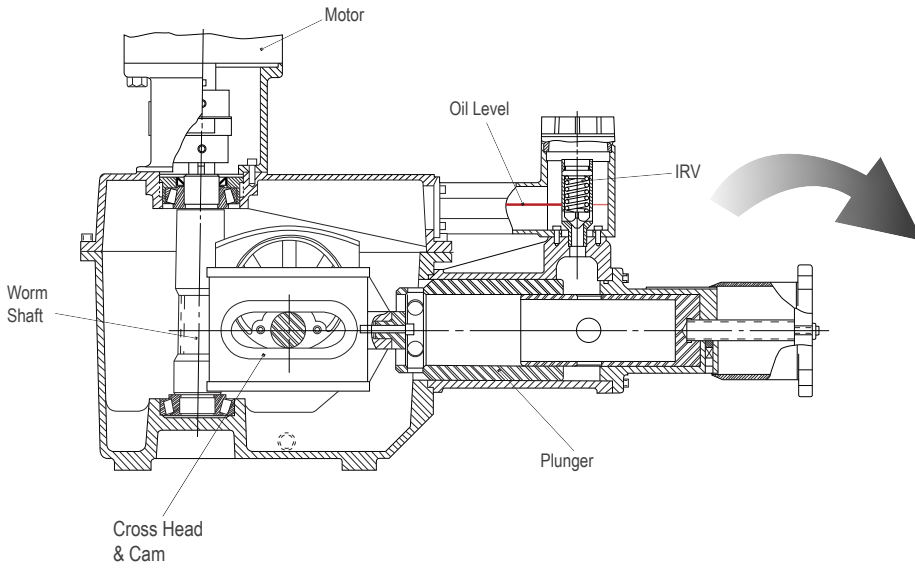

Liquid End (Metallic)

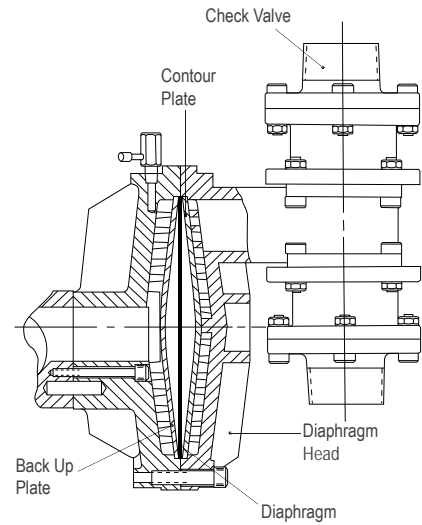

DIMENSIONS

(Shown: Typical Series 4000 Model with Metallic Liquid End and 2-1/2" NPTM Discharge/Suction Connections)

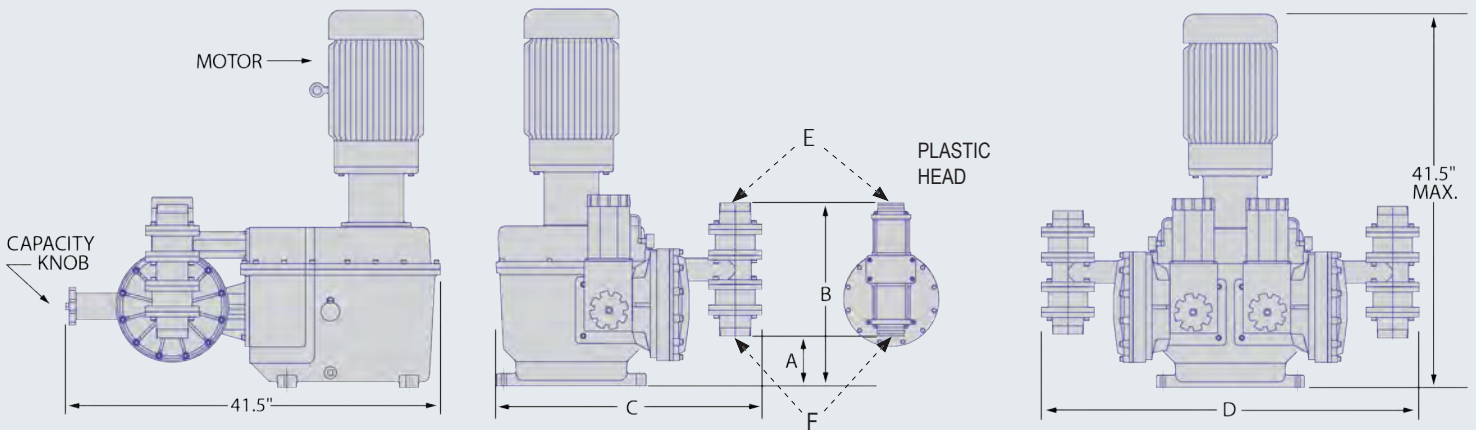

Series 4000, Duplex

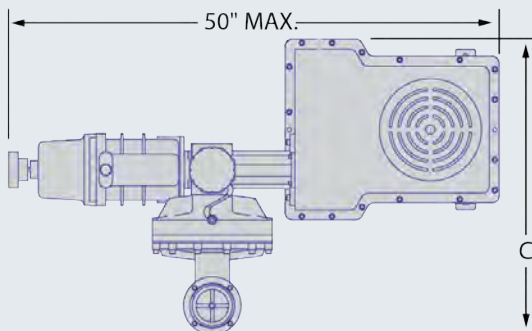

Series 4000 with ECCA

	A	B	C	D	E (NPT)	F (NPT)
Metallic	5-3/4"	19-1/8"	29-1/2"	37-1/2"	1-1/2" to 4" M	1-1/2" to 4" M
Plastic	4-1/8"	24-5/8"	34"	47-5/8"	2-1/2" M	2-1/2" M

*Standard weight is 250 lbs. Varies depending on material and configuration.



Features

- Flow capacities up to 6.5 GPH (Duplex)
- Pressure Up to 3000 PSI
- Modular design in aluminum housing
- Metering accuracy +/- 1%
- Easy capacity controls – Manual/Auto
- Built in safety – Internal relief valve
- Available in duplex to double flow capacity

Specifications

Flow capacity adjustment: 0-100%
While the pump is running or stopped

Turndown Ratio **Metering accuracy**
Stroke length – 10:1 Steady state: +/- 1 %
Stroke frequency – 10:1 Linearity: +/- 1%
Combined – 100:1 Combined: +/- 1%

Maximum process fluid temperature

Custom engineered metallic liquid end: 500°F
Metallic liquid end/PTFE diaphragm: 250°F (121°C)
Plastic Head: 140°F (60°C)

Oil Capacity

Hydraulic oil: 1 qt.
ATF: 1 qt.

Plunger Stroke

Stroke length: 3/4"

Displacement per stroke – by plunger size

3/16" - 0.0207 cu. in. (0.33 ml)
1/4" - 0.0368 cu. in. (0.60 ml)
3/8" - 0.0828 cu. in. (1.35 ml)

Liquid End Material Options

316 SS, Alloy 20, Hastelloy C,
PVC, PVDF and PTFE

SERIES 900 PERFORMANCE TABLE

AquFlow Model Number	Capacity GPH (LPH)	Pressure PSIG (bars)	Speed (SPM)	Plunger Diameter	Connection (Metallic - NPT)
DM3T 1929-0X013	0.14 (0.53)	3,000 (200)	29	3/16"	1/4"
DM3T 1958-0X013	0.28 (1.06)		58		
DM3T 1997-0X013	0.47 (1.78)		97		
DM3T 1912-0X013	0.56 (2.12)		117		
DM3T 1914-0X013	0.67 (2.54)		140		
DM3T 1917-0X013	0.82 (3.10)		170		
DM3T 2529-0X013	0.24 (0.91)	3,000 (200)	29	1/4"	1/4"
DM3T 2558-0X013	0.49 (1.85)		58		
DM3T 2597-0X013	0.82 (3.10)		97		
DM3T 2512-0X013	1.00 (3.79)		117		
DM3T 2514-0X013	1.19 (4.50)		140		
DM3T 2517-0X013	1.44 (5.45)		170		
DM3T 3829-0X013	0.55 (2.08)	3,000 (200)	29	3/8"	1/4"
DM3T 3858-0X013	1.11 (4.20)		58		
DM3T 3897-0X013	1.86 (7.04)		97		
DM3T 3812-0X013	2.24 (8.48)		117		
DM3T 3814-0X013	2.69 (10.18)		140		
DM3T 3817-0X013	3.25 (12.30)		170		

X = 4 for 316 SS, 5 for ALLOY 20, 6 for HAST. C, 8 for PVC, A for PVDF

PERFORMANCE CURVE - TYPICAL

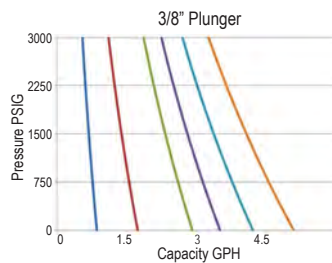
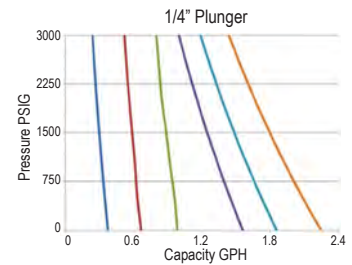
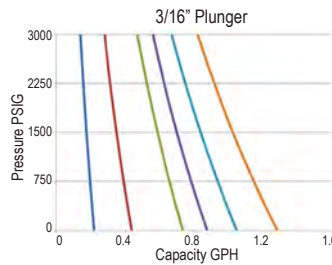

29 SPM — 58 SPM — 97 SPM — 117 SPM — 140 SPM — 170 SPM

ULTRA LOW FLOW SERIES

Designed Specifically for Low Flow Applications
IN Oil & Gas, Pharma, Cosmetics, Food &
Other Industrial Applications.

Lowest Flow Hydraulic Diaphragm Metering
Pump On the Market Made In Compliance API
675.

CROSS SECTION

Standard Model

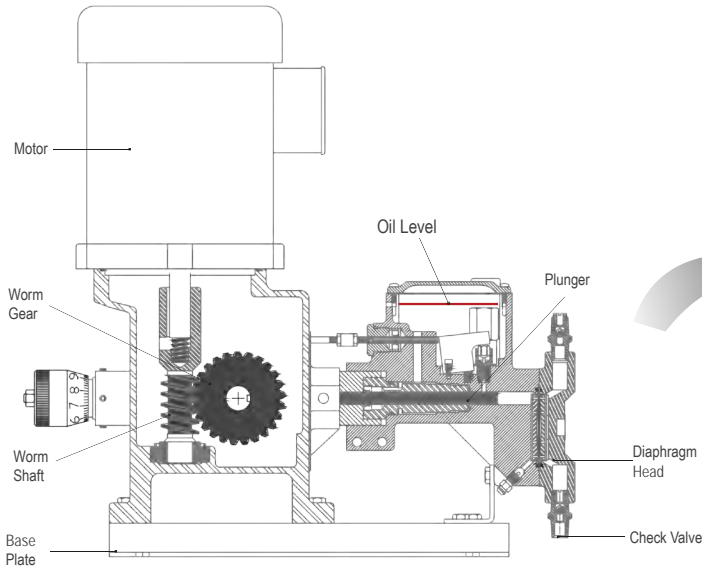

Liquid End (Metallic)

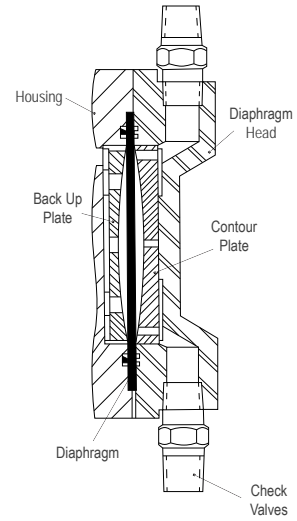

DIMENSIONS

(Shown: Typical Series 900 Model with Plastic Liquid End and 1/4" NPTM Discharge/Suction Connections)

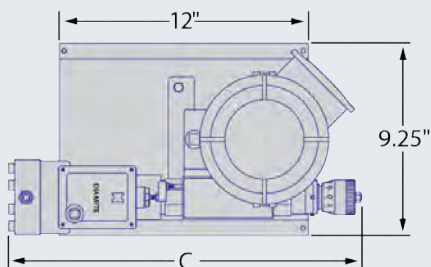
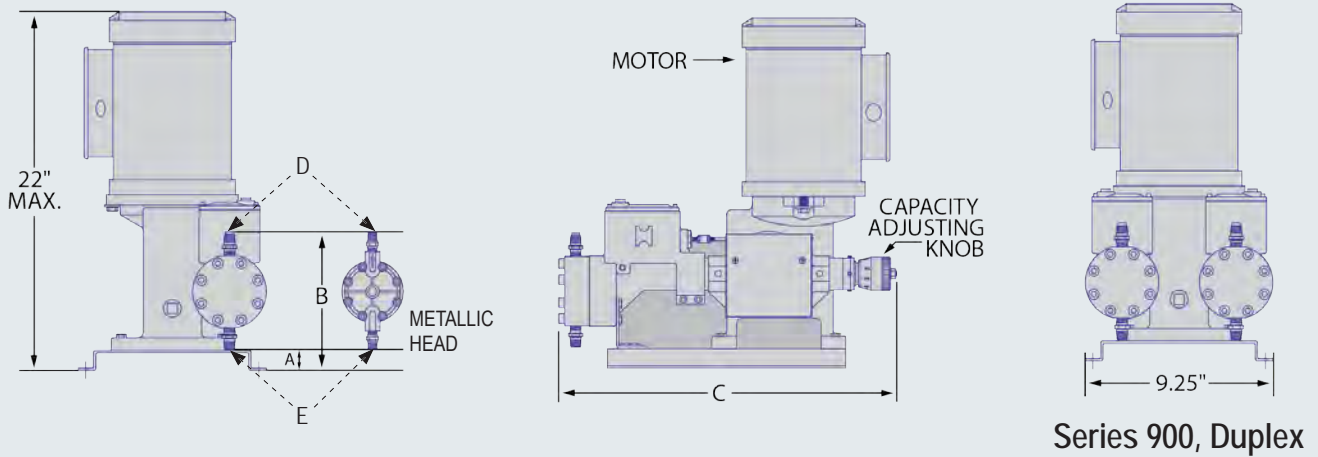

	A	B	C	D (NPT)	E (NPT)
Metallic	1/2"	7-3/8"	17-1/2"	1/4" M	1/4" M
Plastic	1/2"	7-3/8"	18-1/2"	1/2" M	1/2" M

*Standard weight is 75 lbs. Varies depending on material and configuration.

AQUFLOW HYDRAULIC METERING PUMP MODEL CODE

TYPICAL AQUFLOW MODEL: AAAB CC(C)DD-EEFFGHY Please see below for breakdown of this code

AAA: AQUFLOW PUMP SERIES IDENTIFIER

Series 900 - DM4 (Standard), DL4, DL3, etc.
 Series 1000 - CJ4 (Standard), CA4, CJ3, etc.
 Series 2000 - CD3 (Standard), CR3, CQ3, CL3, etc.
 Series 3000 - CNI (Standard), KBI, HFI, CMI etc.
 Series 4000 - GNI (Standard), GMI etc

B: MAIN PUMPING ELEMENT

T = Single PTFE Disc Diaphragm
 W = Double PTFE Disc Diaphragm
 A = Single Hypalon Tube
 B = Single Viton Tube
 S = Suction Lift

CC/CCC: PLUNGER DIAMETER

Series 1000	Series 3000
38 = 3/8"	08 = 1"
56 = 9/16"	10 = 1-1/4"
75 = 3/4"	12 = 1-1/2"
87 = 7/8"	14 = 1-3/4"
113 = 1-1/8"	16 = 2"
162 = 1-5/8"	18 = 2-1/4"
	20 = 2-1/2"
Series 2000	Series 4000
05 = 5/8"	07 = 7/8"
06 = 3/4"	08 = 1"
08 = 1"	09 = 1-1/8"
10 = 1-1/4"	13 = 1-9/16"
12 = 1-1/2"	20 = 2-1/2"
	24 = 3"
	32 = 4"

DD: STROKES PER MINUTE

29 = 29 SPM
 44 = 44 SPM
 58 = 58 SPM
 88 = 88 SPM
 97 = 97 SPM
 12 = 117 SPM
 14 = 140 SPM
 17 = 170 SPM
 19 = 190 SPM

EE: Liquid End Material

04 = 316 Stainless Steel
 05 = Alloy 20
 06 = Hastelloy C
 08 = PVC
 0A = Kynar (PVDF)

FF: Configuration Code

01 = Simplex Manual Adjustment
 02 = Duplex Manual Adjustment
 03 = Simplex Pneumatic Adjustment
 04 = Duplex Pneumatic Adjustment
 05 = Simplex Electronic (4-20mA)
 06 = Duplex Electronic (4-20mA)

G: Valve Ball Size

3 = 1/4" 8 = 7/8" D = 2"
 4 = 3/8" 9 = 1" E = 2-1/4"
 5 = 1/2" A = 1-1/4" F = 2-1/2"
 6 = 5/8" B = 1-1/2" G = 3"
 7 = 3/4" C = 1-3/4" H = 4"

H: LIQUID CONNECTION

Blank = NPT
 F = Flange

Y: SPECIAL CONFIGURATION

Blank = No degassing valve
 D = Degassing valve
 HP = High pressure

Capacity Control Options

The capacity of these pumps can be adjusted by adjusting the stroke length and stroke speed.

Capacity Control Options: All AquFlow pumps come with manual stroke length controls.

Stroke Length Controls: Manual - Standard on all pumps
Electric - Electric stepper motor. Capable of 4-20mA input
Pneumatic - Runs on 30 PSI air for hazardous environment

Stroke Speed Controls: Variable Frequency Drive - AC/DC

Leak Detection Options

Leak Detection: There are two types of leak detection options available with AquFlow pumps.

Conductive: Conductivity probe between 2 diaphragms to sense any break/rupture.

Vacuum: Uses a vacuum switch between 2 diaphragms to sense rupture/ failure.

Liquid Handling Options

AquFlow pumps are used with many kinds of liquids, some of which may need special configurations.

Tubular: For liquids with suspended solids/slurries that may clog. Perfect fit for high viscosity liquids.

Degassing Valve: Some challenging liquids can cause air locking due to off gassing. Our pump head with degassing valve ensures accurate and consistent pumping by expelling gas bubbles from the pump head.

Double Ball Check Valve: To ensure you have positive valve shut off.

Tungsten Carbide Valve Balls: For abrasive liquids.

Other Options

Liquid Connections - NPT / FLANGE/ TRICLAMP

Motor Options: Enclosure: TEFC, TENV, Explosion Proof, Washdown
 Power Supply: ACV 115V, 230V, 380V, 460V, DC-12, 24, 90, 180, Single Phase, 3-Phase.

Pump Controls



ADJUSTING STROKE LENGTH

MANUAL CONTROL

Our standard hydraulic diaphragm metering pump's volume (capacity) can be adjusted from 100% down to 10% by changing the stroke length without compromising the accuracy. Our pumps are factory set at 100% of the maximum pump capacity and can be adjusted by turning the manual knob to the preferred percentage. The stroke length of AquFlow pumps can be adjusted while the pump is running. This makes achieving the exact amount of flow quick and easy.

ELECTRONIC CAPACITY CONTROL ADJUSTER

AquFlow's Electronic Capacity Control Adjuster (ECCA™) permits the automatic control of pump capacity by changing the stroke length. Replacing the standard manual micrometer knob and mounting directly on the pump, the ECCA uses miniaturized, state-of-the-art electronic technology built around an AC synchronous motor. This permits precise actuator travel, without hunting or overshoot.

INTELLIGENT VERIFICATION AND CONTROL SYSTEM (IVAX)

Controlling an AquFlow chemical metering pump can be done by regulating the capacity of the pump via the electrical capacity control actuator (ECCA), the speed of AC motors via the Variable Frequency Drive (VFD) or DC motors via SCR. The ECCA and the VFD have a 4-20 mA signal input and feedback output. The major components of the IVAX are the HMI/PLC, the Magmeter, the ECCA, and the VFD. Customers can choose to control the pump via the VFD, the ECCA or both.

PNEUMATIC CAPACITY CONTROL

AquFlow's Pneumatic Capacity Control (PACO™) permits the automatic adjustment of pump capacity. Replacing the standard manual micrometer knob and mounting directly on the pump, the PACO permits remote capacity adjustment from a manual loading station and/or a response to an instrument air signal from a process controller.

ADJUSTING STROKE SPEED

VARIABLE FREQUENCY DRIVE

The HydroDrive™ AC Variable Frequency Drive is a variable speed control in a NEMA 4X (IP-65) washdown, watertight enclosure. It is designed to operate 208-230 Volt 3-Phase AC induction motors through 3.6 Amps RMS. The sine wave coded Pulse Width Modulated (PWM) output operates at a frequency of 16Hz which provides high torque and efficiency at a low noise level.

VARIABLE SPEED DRIVE

Specifically designed for use with metering pumps, the AquFlow™ HydroDrive™ DC SCR Variable Speed Drive is a NEMA 4X (IP-65) variable speed motor control for shunt wound or permanent magnet motors. Its rugged, die cast aluminum housing is protected with an acrylic coating for maximum corrosion resistance, making it suitable for application requiring washdown, watertight integrity. All switches are sealed with rubber boots and the manual speed adjustment potentiometer incorporates a shaft seal.

DUAL AXIS PUMP CONTROL

By combining both stroke length and speed we get control and fine resolution. Use either the manual or automatic stroke length adjuster with the VFD to control pump speed.

TYPICAL AQUFLOW PUMP INSTALLATION

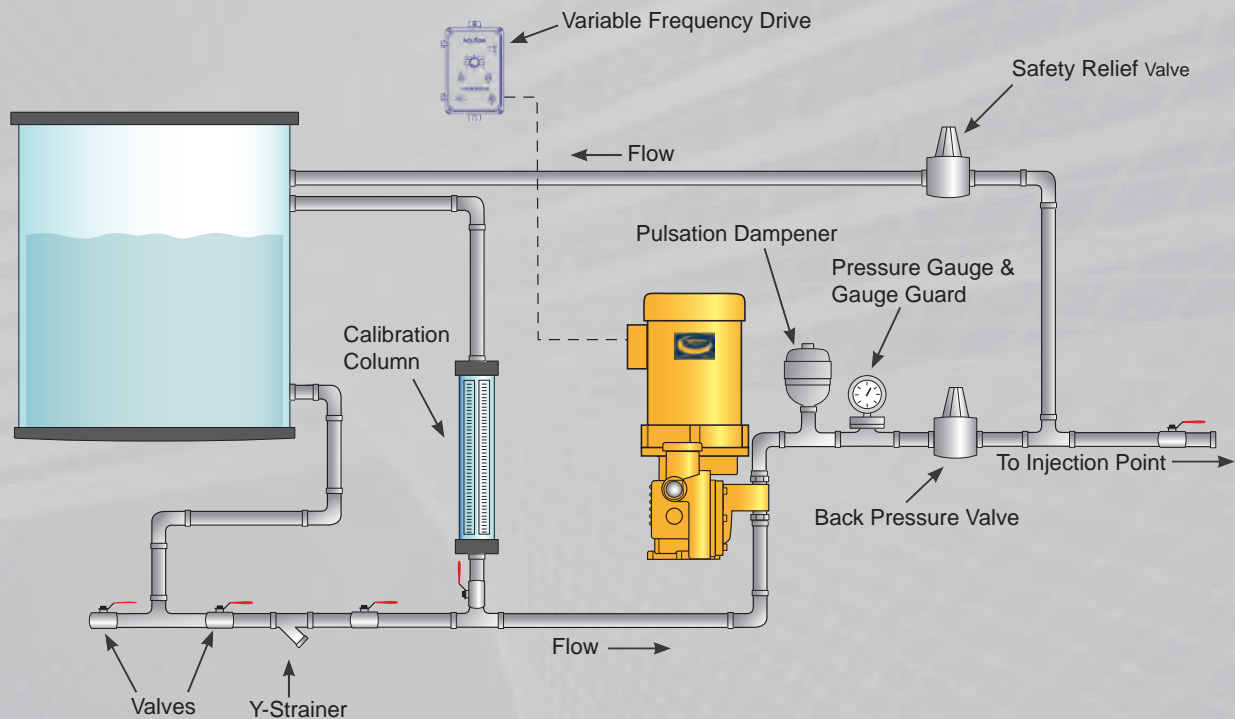

AQUFLOW PUMPS WORK BEST WITH AQUFLOW ACCESSORIES

Calibration Columns:

- Help calibrate the pump accurately
- Should be based on the flow rate and chemical compatibility to the fluid
- Available as 0-10 liters in PVC, Stainless Steel etc.

Back Pressure Valves:

- Maintain steady shut off pressure for valves
- Allow for repeatability of a constant fluid discharge per stroke
- Available as 3/8" to 2" in PVC, Stainless Steel, Alloy 20, PVDF, Hast. C

Safety Relief Valves:

- For additional layer of safety from over pressurization
- Used when pumps are capable of higher pressure than the discharge line pressure
- Available as 3/8" to 2" in PVC, Stainless Steel, Alloy 20, PVDF, Hast. C

Pressure Gauge with Isolator:

- To visually see the functionality of the pump
- Isolator separates internal components from chemicals
- Available in PVC, Stainless Steel, Alloy 20, PVDF, Hast. C

Pulsation Dampeners:

- To get a pulse-less, steady flow
- Removes a high degree of pulsing and surging in the line
- Available as 0-10 liters in PVC, Stainless Steel, Alloy 20, PVDF, Hast. C.

Flow Meters:

- Detect low flow rate as low as 1.8 GPH
- Compatible with most chemicals

Strainers: To keep the debris away from check valves



Cheminjector Systems



CUSTOMIZED RELIABILITY - COMPLETE CHEMICAL FEED SYSTEMS

EVERYTHING YOU NEED FOR ACCURATE CHEMICAL DELIVERY IN YOUR PROCESS

- Tell us your chemical dispensing requirements. We will build a customized system for you.
- We will also provide you with system automation to match your needs.
- A complete turnkey system that can perform dependably and durably with minimal down time.

FROM CHEMICAL TANK TO INJECTION QUILL – COMPATIBLE ACCESSORIES

- We have pre-matched every component that goes in the system. No incompatibility issues.
- Tested components and controls to ensure optimal performance.
- One responsive team. Comfort in knowing you can call one team known for its responsiveness.

AVAILABILITY OF ALL SERVICE PARTS UNDER ONE ROOF

- We maintain adequate inventory of critical service parts to ensure minimal down time
- Our vendors also support us with similar availabilities for outsourced parts
- Since we maintain complete records for all CI systems built we can always get right parts.

SKID MOUNTED, MOBILE STATIONS, SITE MOUNTED, VEHICLE MOUNTED OPTIONS

- While most assemblies are skid mounted which is then placed at the site there are some systems that are too big for skid mounting. For such systems we provide on site assembly.
- Where mobility is important, we have built mobile systems mounted on carts / trailers or even mounted directly on a vehicle for covering long distances.

STANDARD RANGE OF CHEMINJECTOR PACKAGES

CHEMINJECTOR BASIC ASSEMBLY

- Essential Accessories like Back Pressure Valve, Pressure Relief Valve, Inlet and Discharge Valves, Connecting piping mounted on a simple skid along with the pump and motor.

CHEMINJECTOR STANDARD SYSTEM

- In addition to the Basic Assembly components we add Calibration Column, Inlet Strainer, Pressure Gauge with Isolator, Control Panel with On / Off Switch.

CHEMINJECTOR AUTO SYSTEM

- This includes automation controls which can be communicated with a 4-20mA signal from a computer or a SCADA. Capacity is adjusted with either a VFD or ECCA (Stroke Adjuster).

CHEMINJECTOR AUTO PLUS SYSTEM

- This also includes a feedback loop from a flow meter to ensure the accurate delivery of the chemical. This system also comes with an optional memory for record keeping.

CHEMINJECTOR AUTO PLUS REMOTE CONTROL SYSTEM

- As the name suggests this system has the additional capability to be controlled remotely using a radio signal or over the internet using a computer, tablet or a smart phone.

AQUFLOW WARRANTY – INDUSTRY LEADING

For Hydraulic diaphragm metering pumps Manufactured in the USA!

AquFlow has been manufacturing premium quality hydraulic diaphragm metering pumps for over 40 years since 1972. We have refined the design and perfected the performance over that period to earn a reputation as a maker of long lasting durable pumps that never quit. We have numerous testimonials from our customers who had made the change from competitive pumps to AquFlow never to buy another brand again.

It is with this confidence that AquFlow offers a limited warranty for all its hydraulic diaphragm metering pumps that are manufactured in Irvine, California, USA up to 3 years on all prequalified applications.

OTHER PUMP LINES WE CARRY INCLUDE: XTRAFLOW PROGRESSING CAVITY PUMPS

XTRAFLOW sells progressing cavity pumps with top notch mechanical components to increase performance. The patented pin joint allows the pump to be completely reversible and sustain constant high pressures. Rotors are available in small to large, with many options to meet all your process demands. Progressing cavity pumps are strong and compact, but precise geometry remains with big solid passages for max suction.

Range: Diamond series, Dosing, Flanged, Hopper, Bridge breaker, Food grade, Vertical, Grinder AND MORE



TAPFLO AIR OPERATED DIAPHRAGM PUMPS

Tapflo America sells high end Air Operated Diaphragm pumps made by Tapflo a Sweden based manufacturer. Tapflo has a complete line of AODD pumps made out of corrosion resistant plastics and metals. Their plastic pump housings are machined out of solid block of material which ensure tighter tolerances and hence better sealing surfaces. This ensures longer leak free life in comparison to molded plastic pumps.

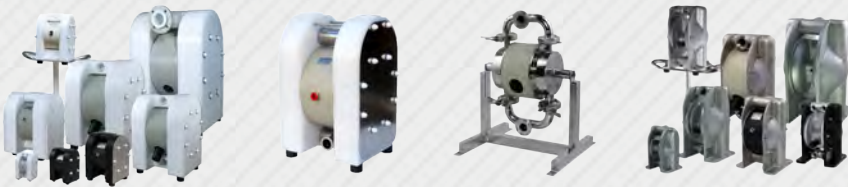

Tapflo is also known for their line of sanitary and pharmaceutical pumps. Tapflo makes the only USP Class VI certified line of pharmaceutical pumps. Flow rates over 212 GPM in sizes up to 3" inlet and outlet.

FOLLOW US ONLINE:



AQUFLOW



AQUFLOWPUMPS



The Most Complete Line of Metering Pumps

S 900 - 0 to 0.012 GPH, up to 3.0 GPH,
0 to 3000 PSI

S 1000 - 0 to 62 GPH, 0 to 4000 PSI

S 2000 - 0 to 112 GPH, 0 to 1,800 PSI

S 3000 - 0 to 482 GPH, 0 to 700 PSI

S 4000 - 0 to 3,530 GPH, 0 to 3,500 PSI

Corrosion Resistant Materials

316 Stainless Steel, Alloy 20, Hastelloy C
PVC, PVDF, PTFE

ChemInjector Chemical Systems

Complete Customized chemical system
Uninterrupted Consistent Chemical Delivery
Perfectly matched Accessories
Controls that are user friendly and digitized
All Components proven to work well together
Easy to operate, maintain and service
No downtime with parts availability

Distributed By:

AquFlow
1642 McGaw Avenue
Irvine, CA 92614
USA

Ph: 949-757-1753

Fax: 949-757-1687

Email: sales@aquflow.com

Website: www.aquflow.com