

**AcuFlow Pumps.**

**AcuFlow™**

**ECCA™**

**Electric Capacity Control**

**Series 1000 & 2000**



**INSTALLATION, OPERATION AND  
MAINTENANCE MANUAL**

# Table of Contents

Warranty .....	<i>ii</i>
General Description .....	1
Description of Electronic Circuitry .....	1
Power Supply/Driver Card .....	1
Installation Instructions .....	1
Electrical Connections .....	3
Signal Inputs .....	3
Specifications .....	2
Startup Instructions .....	3
Calibration of the Circuit Board - Series 1000	
Equipment Required .....	4
Input Amplifier .....	4
Checking Motor Limits .....	4
Setting Ratio Control .....	4
Returning to Service .....	4
Disassembly	
Removal of P.C. Card .....	4
Removal of Synchronous Motor .....	5
Removal of Actuator Housing from Pump Series 1000 .....	5
Removal of Actuator Housing from Pump Series 2000 .....	6
Reassembly	
Installing Actuator Housing on Pump Series 1000 .....	7
Installing Actuator Housing on Pump Series 2000 .....	7
Installation of the Synchronous Motor .....	7
Re-Synchronozation Equipment Needed .....	8
Returning to Service .....	9
Outdoor Installations .....	9
Drawings	
Hookup Diagram - Electronic Capacity Control .....	10
Board Layout - Power Supply Driver .....	11
Board Layout - Input Buffer/Motor Logic .....	12
Electrical Schematic - Input Buffer/Motor Logic .....	13
Electrical Schematic - Power Supply & Drive Card .....	14
Test Cable - Synchronization - Local Control .....	15
Test Cable Hookup Schematic .....	15
Series 1000/2000 Motor Coupling Installation .....	16
ECCA™ Cross Section & Parts List - Series 1000 All Plungers .....	17
ECCA™ Cross Section & Parts List - Series 2000 All Plungers .....	18
Troubleshooting Sequence .....	19
Replacement Part Numbers .....	20
Parts Ordering Instructions.....	21

## WARRANTY

AcuFlow warrants its products against defects in workmanship or material under specified use and service for a period of two years from date of shipment. The obligation and liability of AcuFlow is limited to repairing or replacing (at its option) such allegedly defective units as are returned freight prepaid to NPA's plant. No liability is assumed for warranties of merchantability or fitness for a particular purpose except as specified, or for re-installation costs. Liability for consequential damages (including personal injury) is hereby excluded; liability in any event being limited to the original purchase price of the goods involved.

Defects shall not include failure by erosion, abrasion, chemical action, material compatibility, or operation of products outside of the recommended performance envelope. The component materials set forth in the proposal and/or the specifications of an order are recommended by AcuFlow for the particular application. But such recommendations shall not be construed as a warranty or guarantee against wear and/or corrosion, and such recommendations are subject in all cases to verification and acceptance by the purchaser. When repairs or replacements are made under our warranty, incoming freight costs must be paid by the purchaser.

NIKKISO Pumps America, Inc. will not be responsible for work performed by others. AcuFlow reserves the right to void applicable warranties if work performed by others is determined by AcuFlow to be improper.

**Read this instruction completely before installing,  
operating or servicing AcuFlow® ECCA™ Electric Capacity Controllers!**

**Always keep safety considerations foremost! Use proper tools, protective clothing and eye protection when working, and install the equipment with a view toward assuring safe operation. Be extremely careful when working in the presence of hazardous substances!**

# ACUFLOW™ ECCA™

In this instruction manual, the **Note**, **CAUTION** and **WARNING** notations have the following meanings:

**Note:** This heading is used if a special feature or operating requirement is being pointed out.

**CAUTION:** This heading is used to denote when failure to follow the operating instructions as prescribed herein can lead to pump or system damage.

**WARNING:** *This heading is used to denote when failure to follow the operating instructions as prescribed herein could result in **PERSONAL INJURY!***

## GENERAL DESCRIPTION

The electric capacity control actuator can be furnished in place of the standard manual micrometer adjustment. The actuator adjusts pump capacity from an electronic signal or manually by means of an override handwheel. Local capacity indication is read directly from an indicating scale on the actuator, or remotely by use of the electronic retransmission signal (4-20 MADC) feature. Control is achieved through the use of down sized state of the art electronics and synchronous motor technology in a single compact enclosure.

### Synchronous Motor

The use of this type of motor permits rapid response and precision positioning in a small package. Since this kind of motor is magnetically detented, overshoot is eliminated, a problem inherent in shaded pole or gear motors.

### Electronics

The operation of the electric capacity control actuator is controlled by two electronic circuit cards. The top one serving as the input and logic section and the bottom serving as the power supply and motor driven section. These circuits accept an input signal from a process instrument and commands the synchronous motor to drive to a corresponding position. Closed loop positioning is accomplished through use of a feedback slide wire.

## Description of Electronic Circuitry

### Input Buffer/Motor Logic 17007

1. **Input Buffer Amplifier:** The input voltage signal is converted from 1-5 VDC to a 0-10 VDC signal using a high impedance amplifier, U4A. This voltage is applied to the ratio control which is used to scale the signal to the appropriate value. The resultant voltage is the positive input to the error amplifier, U4B, which compares it to the actual capacity control position as represented by the negative feedback potentiometer which is gear driven by the actuator motor.
2. **Error Amplifier and Motor Logic:** The error developed at U4B is applied to two comparators, U5A & U5D, which have slightly different set points. Any error in excess of these pre-selected values will cause the motor logic, U6A or U6B, to respond with either an up (+) or down (-) signal. The signal then enters the motor drive Section which provides current amplification through transistors Q3 or Q4.
3. **Feedback Buffer:** The previously mentioned feedback potentiometer picks off a voltage from +5 VDC to -1.2 VDC, depending upon its position as the motor rotates. This voltage is applied to the feedback buffer amplifier for comparison with the input signal. At the same time, this signal is applied to the electronic limiting circuitry U5B and U5C. These comparators are set (via high and low potentiometer) to limit actuator travel in the event of an overdriven or underdriven input.

### Power Supply/Driver Card 17006

#### Power Supply

The transformer output is rectified by a full wave bridge, filtered and routed to a pre-regulator stage. This darlington pair is controlled by zener CR3 referenced to the output of the primary regulator, U1. The 5 volt reference U2 is tied to U1 through a dropping diode CR2 and held 1.2 VDC above the supply return in order to permit live zero voltage feedback potentiometer operation without offset.

#### Motor Driven

The current amplified up and down signal enters the motor driver selection at pin two of the optically isolated triac drivers U7 and U8. These optoisolators

## SPECIFICATIONS

Input voltage:		120 VAC 50/60 hz single phase
Power consumption:		44 va maximum
Line protection:		Fuse type, 3 amp Bussman PCC3
Line voltage variations:		±10% of nominal
Line frequency variations:		±2% 50/60 hz
Ambient temperatures:		0-40°C (32-104°F)
Relative humidity:		5-96% (witout condensation)
Altitude:		3300 feet (1000 meters)
Motor type:		AC synchronous (impedance protected)
Response time:	Series 1000	8 seconds
0-100%	Series 2000	16 seconds
	200	8 seconds
	Series977/997	8 seconds
Turndown ration:		better than 20:1
Repeatability:		±1%
Drive connection:		Direct on Series 900, 1000, 2000 and Hydromyte
Input signal voltage:		1-5 VDC, 3 meg ohm impedance
current:		4-20 MADC, 250 ohm impedance
Output signal voltage:		1-5 VDC across a 250 ohm resistor
Current:		4-20 MADC into 500 ohms maximum
Adjustments:	High limit	factory set
	Low limit	factory set
	Span	factory set
	Zero	factory set
	Gain	field adjustable, 4-20 retransmission
	Offset	field adjustable
	Ratio	field adjustable 100%
Field connections:		AC power Process signal in-captive wire type Position signal out-captive wire type Motor disable-MTA . 100" 2 Pin
Enclosure type:		NEMA 4 standard NEMA 7 optional (class 1, div. 1, group C and D)
Indicator type:		Local - mechanical Remote - 4-20 MADC into 500 ohm or 1-5 VDC across 250 ohm
Actuator control:		Electronic comparator with synchronous motor and mechanical manual override
Actuator limits:		Electronic - no limit switches

### ACTUATOR MODEL SELECTION

ACTUATOR MODEL NO.	MODEL OF PUMP WHERE USED	SERIES OF PUMP WHERE USED
17100-1100	AcuFlow	1000
17100-2100		2000
17100-3100		3000
17100-4100		4000
17100-5100		977/997
17100-5100		200

trigger triacs CR4 or CR5 which are directly coupled to the directional windings of the capacity adjusting motor.

## INSTALLATION INSTRUCTIONS

The electric capacity control has been factory tested and calibrated on the pump prior to shipment. No further field adjustments or calibrations to the factory settings should be necessary prior to placing unit into service.

**Note:** To maintain correct alignment and support, it is recommended that the pump/actuator combination remain bolted to its factory supplied base plate for Series 200, 977, 997, 1000 and 2000 pumps.

**CAUTION:** Do not adjust capacity handwheel beyond the limits of the indicating scale or damage to the pump and actuator may result.

### Electrical Connections

1. Unscrew end cover to expose with connection points. Refer to drawing on page 12 for hookup diagram.
2. Power and signal wires SHOULD BE RUN SEPARATELY. Use shielded cable for signal line. The electric capacity control requires a power source of 120 VAC 50/60 hz single phase. The branch circuit should be protected by a fuse or circuit breaker and contain a disconnect switch. The circuit boards are protected by a self contained fuse.
3. The black wire should be the phase side of the line and connect to terminal "L"; the neutral or white wire to terminal "N". Equipment grounding is effected by connecting a green wire to one of the screws in the housing, the other end of this wire is returned to protective ground at the source of supply.

**Note:** Appropriate conduit hubs must be used, and all covers must be in place and tight to prevent liquid entry and maintain NEMA integrity.

### Signal Inputs

1. The electric capacity control accepts a voltage signal of 1-5 VDC. If the controlling signal is a current signal, the 249 ohm resistor (R133) will transform it into the voltage required. It may be left in place when a voltage signal is used, but

the transmitter must be low impedance output. Better practice is to remove the resistor completely.

2. The 249 ohm resistor is the correct value for 4-20 MADC input. This resistor (R133) is located adjacent to J1 and in back of TB1 on the input buffer/motor logic card (17007). If a high impedance voltage source is used, the resistor can be removed by carefully clipping the lead at the resistor body (R133).
3. Connections have been provided that allows the actuator to be disabled. A N.O. dry contact connected to J1 (when closed) will disable the motor drive circuit while allowing the remaining circuitry to be fully activated. This permits the actuator to be set and then disabled, while still transmitting a positioner signal (4-20 MADC). It also permits manual override while the unit is powered up. Connections to J1 are made via an MTA two pin connector on .100" Centers.

## START UP INSTRUCTIONS

1. Apply power to the actuator and inject a 4 MADC signal at B1 to bring the actuator to zero percent capacity. Place a mark on the slotted coupling (3409 drawing 17017, 17018). Inject a 20 MADC signal and count the number of turns. For Series 1000, 977, 997 and 200, there should be ten turns for 100% output. For Series 2000, there should be twenty turns for 100% output. Any differences can be corrected by adjusting the ratio potentiometer R130 on input buffer board 17007.

The electronic limiting feature built into the actuator circuitry permits only a few degrees of positioner rotation past 100%, likewise, a few degrees below zero percent. This is to prevent mechanical jamming of the actuator. When adjusting the actuator by means of the override handrail, it is important to maintain indicator travel within the limits of the indicating scale, or damage to the actuator can occur. The manual override should be used in conjunction with the actuator disable feature or with power removed from the actuator. See section 3, under "SIGNAL INPUTS" for the actuator disable feature.

2. The ratio control potentiometer is used to adjust the full scale output of the pump for a full scale input signal. If it is desirable to have less than 100% pump output for a 100% input signal, the ratio control pot should be turned in a

counterclockwise direction from its normally midscale position. If 100% output is required for less than 100% input signal, the pot should be adjusted in a clockwise direction. Small adjustments are in order because of the high gain system employed. (Any change in the ratio control from the factory setting will require recalibration of the pump).

3. Remote indication or closed loop operation can be accomplished using the 4-20 MADC retransmission feature located at TB3. "COM" is the low or negative side and "OT" is the high or positive side. Apply 4 MADC to the input, (allow actuator to position itself) and adjust the gain pot to 20 MADC output. Since the offset and gain pots interact with each other, several adjustments from 4 to 20 MADC may be required to complete the calibration. The input and output signals are isolated from phase and ground but not from each other. The maximum load that can be connected across TB3 is 500 ohms.

## **CALIBRATION OF THE CIRCUIT BOARD - Series 1000**

**Note:** The P.C. Cards are tested, calibrated and matched to each actuator motor and pump at the factory, and are ready to be placed into service as received. The following instructions are included as an aid in troubleshooting in the unlikely event of a malfunction.

### **Equipment Required**

1. 120 VAC supply.
2. Adjustable DC voltage source capable of simulating 1-5 VDC or a current source capable of 25 MADC.
3. A digital voltmeter reading .01 volts minimum.
4. Miscellaneous jumpers.

Extent of Calibration: This procedure covers the setting of the zero and the span potentiometer, checking the high and low limit potentiometer, and setting the ratio control. This procedure assumes that the input signal range is 1 to 5 VDC, or 4-20 MADC.

Preliminary: Connect (but do not turn on) the AC power to terminal L&N (TB2) on power supply board 17006. Safety ground can be connected at the housing or under the screw head of a standoff. Connect adjustable DC voltage supply to terminal C-and V1 + (TB1) on input board 17007.

### **Input Amplifier**

1. Apply line power to board. Read voltage from TP2 & to C-.
2. Connect a jumper (across the zero pot) from R102 (inside leg) to C. Apply 5 VDC to input and adjust span pot for 12.5 VDC at TP2.
3. Remove jumper across zero pot. Apply 1 volt to input and adjust zero pot for 0.0 V at TP2.
4. Apply 5 VDC to input and adjust span pot for 10 VDC. All voltages are  $\pm 0.1$  VDC.
5. Repeat steps 3 and 4 as required.

Motor Limits: The high and low potentiometers on the input board are factory set for each actuator/pump combination and require no further adjustment.

### **Checking Motor Limits**

1. Input 0.98 VDC. Read voltage from test point h (+) to common.
2. Input 0.94 VDC. Observe that voltage goes on high.
3. Input 2 VDC then 0.98 VDC. Observe that voltage goes on high.
4. Input 5.08 VDC. Read voltage from test point g (+) to common. Observe that voltage is high.
5. Input 5.13 VDC. Observe that voltage goes low.
6. Input 4 VDC then 5.08 VDC. Observe that voltage goes high. This procedure is for checking proper operation of motor limits only.

**Note:** The above voltages are typical and will vary with pump/actuator combination.

### **Setting Ratio Control**

1. Input desired voltage for full scale operation.
2. Adjust ratio potentiometer for desired pump output, turn clockwise to increase output, counterclockwise to decrease output.

### **Returning to Service**

1. Remove power and disconnect all test equipment and jumpers.
2. Reconnect power and input/output signal cables if other sources were used for calibration check.
3. Replace all covers securely to maintain NEMA integrity.

## **DISASSEMBLY**

### **Removal of P.C. Cards**

1. Remove and lock out power and signal to actuator and pump.
2. If possible set pump to 0% capacity using manual override hand wheel and capacity scale.
3. Remove cover from actuator.
4. Disconnect incoming power and signal lines and outgoing signal line if used.
5. Remove feedback potentiometer cable from P2 on card 17007.
6. Remove motor control cable from P1 on bottom card 17006.
7. Remove the three screws (3417) retaining the motor logic card to standoffs (3548). Drawings 17018 & 17017 (depending on Series of pump).
8. Remove the three standoffs (3548) retaining power supply to standoffs (3547).
9. Unplug phase shift network leads from the wires on the underside of the power supply card.
10. Remove P.C. Cards as a pair and place them in a safe location. Care must be taken to prevent breakage of interconnect cables.

### **Removal of Synchronous Motor**

1. Remove the three standoffs (3547) attached to the motor plate (3402). It is recommended to identify these standoffs soles on the motor plate for reassembly later on. These standoffs are two inches long and should not be confused with standoffs (3458) which are one and one half inches long. Clip off and discard any tie wraps retaining interconnect wiring to these standoffs (3547).
2. Remove the Zerust anticorrosion pad then remove the four flathead screws (3416) retaining the motor plate (3407) to the four motor standoffs (3415). Carefully remove the motor plate assembly and inspect all components for breakage or wear. Replace worn or broken potentiometer and drive gears. It may be necessary to loosen (not remove) the pot bracket screws on the lower side of the motor plate (3407) to allow removal of motor plate assembly from actuator housing.
3. Remove the four motor standoffs (3415) retaining the motor in place. The motor is placed inside the actuator housing with the connector

at the three o'clock position relative to the conduit entry holes. During reassembly the motor must be installed in this same position.

4. Carefully remove the motor and inspect for wear or breakage of the drive components. The motor shaft must turn freely, but will exhibit a detented or slightly "rough feeling" when turned by hand. The motor must be replaced if the shaft is hard to turn or "frozen". Check the motor coupling (3431) for breakage or wear. If the coupling is usable be sure the set screws (3432) are tight, securing the coupling to the motor shaft. The motor shaft is flatted and one of the two set screws must engage this flat. It is also advisable to use "retaining" grade Loctite to aid in securing the motor coupling (3431) to the motor shaft. To avoid damage to the motor apply Loctite to the I.D. of the coupling (3431) at the large end before sliding it over the motor shaft. See drawing 17124-1 for coupling replacement procedure.
5. Check the motor gear (3437) for wear or breakage. If the gear must be replaced be sure it is oriented with the teeth facing outward (away from the motor). Care should be taken to assure the spacer under the motor gear is in place before installing the new gear. Reassemble the override coupling (3409) to the motor shaft above the motor gear (3437). If any drive components appear worn (beyond use) or broken, contact ACUFLOW or your local factory representative for replacement parts. See "replacement part numbers".

### **Removal of Actuator Housing from Pump Series 1000**

Most serviceable parts are contained within the actuator housing, and are accessible without removing the housing from the pump. These instructions are provided for your convenience in the unlikely event the housing must be removed.

1. Remove support stud (3425). In most applications this will be a length of "all thread" with accompanying lock washers and nuts.
2. Remove the four screws (3418) retaining the capacity plate (3414) to the actuator housing (3402). This plate has been factory sealed and may require some gentle persuasion to break it free. Set the plate in a safe area.
3. Reach inside the housing, using a flat object (three quarter inch wide machinist scale) and



turn the actuator (3404) until the slotted end of the indicator pin (3413) is accessible through the capacity plate opening. This pin has been factory installed using low shear grade Loctite, use the correct size screwdriver and remove the indicator pin and set it in a safe place.

4. Loosen, but do not remove, the four clamp ring screws (3442). This releases clamp ring pressure, permitting the actuators to be unscrewed from the mounting adapter (3401).
5. Turning counterclockwise, unscrew the actuator housing from the mounting adapter (3401). COUNT THE NUMBER OF TURNS AS YOU GO. This information will be necessary for reassembly of the actuator to the pump.
6. Inspect the indicator ring (3412) and pin (3413) for wear or damage. Replace as necessary,
7. Inspect the actuator coupling (3404) for wear or damage. The actuator must turn freely inside the housing. End movement between housing and actuator is a normal condition though radial movement should be negligible to nonexistent. If excess radial movement is detected, housing (3402) and/or actuator (3404) should be replaced.
8. To replace a worn or damaged actuator (3404), set the housing (3402) on end and reach inside with a pair of snap ring pliers and remove snap ring (3433). This will allow the actuator to be removed from the housing. When replacing the actuator (3404), apply a thin film of moly grease to its minor diameter before inserting it into the housing, and retain it in place using a new snap ring (3433). Electric capacity control disassembly instructions stop at this point. Further disassembly of the pump is covered under separate print. Contact NIKKISO Pumps America, Inc. for this information.

### **Removal of Actuator Housing from Pump Series 2000**

Most serviceable parts are contained within the actuator housing, and are accessible without removing the housing from the pump. These instructions are provided for your convenience in the unlikely event the housing must be removed.

1. Remove the support stud (3425). In most applications this will be a length of "all thread" with accompanying lockwashers and nuts.
2. Remove the four screws (3418) retaining the capacity plate (3414) to the actuator housing

(3402). This plate has been factory sealed and may require some gentle persuasion to break it free. Set the plate in a safe area.

3. Loosen, but do not remove, the two adaptor housing set screws (3429) on adaptor housing (3428). Grasp the actuator housing (3402) firmly and in a clockwise direction, turn the adapter housing (3428) six to eight turns to completely separate actuator housing (3402) from adaptor housing (3428).
4. Inspect capacity indicator and indicator pin for wear or damage. Replace as necessary.
5. To remove the capacity indicator and pin, turn the indicator until the pin is in the vertical position. Support the threaded adjuster (4633) and carefully drive the pin out using an appropriate sized drift (punch). To install a new indicator and pin, support the adjuster and align one of the holes in the indicator over the hole in the adjuster shaft with the raised section if the indicator facing away from the pump housing. Place the pin through the hole in the indicator and hold it in place over the hole in the adjuster (4633). Carefully drive the pin through the hole in the adjuster until there is an equal amount of exposed pin on either side of the adjuster shaft. Care should be taken not to deform the indicator during installation or binding may occur.
6. Inspect the actuator coupling (3404) for wear and damage. Actuator must turn freely inside the housing. End movement between the housing and the actuator is a normal condition though radial movement should be negligible to nonexistent. If excess movement is detected, housing (3402) and actuator (3404) should be replaced.
7. To replace a worn or damaged actuator (3404) set the housing (3402) on end and reach inside with a pair of snap ring pliers and remove snap ring (3433). This will allow the actuator to be removed from the housing. When replacing the actuator (3404), apply a thin film of moly grease to the minor diameter before inserting it into the housing, and retain it in place using a new snap ring (3433). Electric capacity control disassembly instructions stop at this point. Further disassembly of the pump is covered under separate print. Contact ACUFLOW for this information.

## REASSEMBLY

### Installing Actuator Housing on Pump Series 1000

1. Slide the capacity indicating ring (3412) over the actuator (3404) with the raised end toward the housing (3402).
2. Align the housing (3402) with the pump adaptor (3401). Turning clockwise, start and then screw the housing onto the adaptor using the same number of turns required for removal bringing the flattened surface by the conduit entry holes parallel to the base plate (plate the pump is mounted to).
3. Tighten the four clamp ring screws (3442). Check for any radial movement of the housing. If movement is detected, loosen the clamp screw and turn the housing (3402) one turn clockwise and retighten the four clamp ring screws.
4. Turn actuator (3404) to align a slot with the threaded hole in the control spool assembly (3439). Slide the indicating ring (3412) in place, and insert the indicator pin (3413) through one of the two holes in the ring, down through the slot, and into the threaded hole of the control spool (3439). Turning clockwise, screw the indicator pin (3413) through the control spool and down through the hole in the opposite side of the indicating ring (3412). Ends of the pin may not protrude past the raised section of the indicator ring.
5. Remove old sealant from the capacity plate (3414) and its mating surface on the housing. Apply a film of clear RTV (silicone) to the mating surface on the housing and secure the capacity plate in place over the RTV using the four screws (3418).
6. Install the stud (3425) with its hardware into the bottom side of the housing (3402). It may be necessary to loosen the clamp ring screws (3442) to allow slight housing repositioning when installing this stud. Retighten the clamp ring screws first then secure the stud (3425). This stud is intended for support only. Care should be taken when tightening the jam nuts to prevent the introduction of lateral forces that might cause misalignment between the pump and the actuator housing.

### Installing Actuator Housing on Pump Series 2000

1. Apply a thin film of moly grease to the threaded end of adaptor (3428). Align housing (3402), actuator (3404), capacity indicator (3412) and housing adaptor (3428). In a counterclockwise direction, screw the housing adaptor (3402) until intimate contact is made between these two parts. Bring the flat surface of the conduit entry holes in the housing (3402) parallel to the base plate (plate the pump is mounted on). Hold the actuator housing in this position and install the stud (3425) with its hardware into the bottom side of the housing (3402). Tighten the two set screws (3429) first, then secure the stud. It is important to seat the two set screws (3429) in the groove (undercut) portion of the adjuster housing (3436). Stud (3425) is intended for support only, and care should be taken when tightening the jam nuts to prevent the introduction of lateral forces that might cause misalignment between the pump and the housing (3402).
2. Remove old sealant from the capacity plate (3414) and its mating surface on the housing. Apply a film of clear RTV (silicone) to the mating surface on the housing and secure the capacity plate in place over the RTV using the four screws (3418).

### Installation of the Synchronous Motor

The motor assembly must be complete with coupling (3431), spacer, gear (3437), and override coupling (3409). Connector with red, black and white wires is also considered part of the motor assembly and must be in place.

1. Insert the motor into the housing engaging the coupling (3431) with actuator (3404). The motor must sit squarely in its mount with no movement other than rotational.
2. Orient the motor so the connector is at the three o'clock position relative to the conduit entry hole (conduit holes at the twelve o'clock position). Secure the motor in place using the four standoffs (3415). If new standoffs are being used, it is recommended to apply a thin film of grease to the male threads before installation.
3. The motor plate should be a built up assembly of (3407), phase shift network consisting of 2.5UF capacitor and a 500 ohm resistor, and a feedback pot assembly. Locate this motor plate assembly over the four motor standoffs (3415)

with the feedback pot at the bottom (side opposite conduit entry holes). The two feedback pot bracket screws (6-32 x 1/2) should be loose at this time to allow full disengagement of the two gears (3437) and (3438).

4. Install the three standoffs (3547) in the holes identified during disassembly.
5. This step is for Series 1000 pumps only. Turn the motor shaft counterclockwise (via slot on the override coupling 3409) until it reaches its mechanical stop. Then turn the shaft 1/4 turn clockwise. This is 0% capacity of the pump.
6. This step is for Series 2000 pumps only. Turn the motor shaft clockwise (via slot on override coupling 3409) until it reaches mechanical stop. Place a mark on the coupling at the twelve o'clock position. Now, turn the coupling counterclockwise one and one half turns. This is the 100% capacity. Now turn the coupling counterclockwise twenty turns. This is 0% capacity.
7. The pump and the actuator are now ready to be synchronized.

#### **Re-Synchronization Equipment Needed**

- A. 1-5 VDC or 4-20 MADC source.
- B. 115 VAC power cord set.
- C. Test cable with plug, Hydroflo part number 17120-1.

1. Connect feedback pot cable to P2 on input buffer/motor logic card 17007.
2. Connect (do not apply power) 115 VAC cord set to TB2 on power supply/drive card 17006.
3. Connect voltage or current source TB1 on input buffer/motor logic card 17007.
4. Connect test cable plug (ACUFLOW™ part number 17120-1) to P1 on power supply/driver card 17006.
5. Place these two cards on an insulated surface such as cardboard, plastic, etc. Do not allow the two cards to touch each other or any metallic surface.
6. Connect 115 VAC light bulbs with pig tails (any wattage) to the test cable wires. The white wire from P1 is common or neutral to both lights, the black is hot to one light, and the red is hot to the other light. See test cable schematic drawing 17121-1. Do not connect the phase shift network wires at this time.

7. Apply a 4 MADC or 1 VDC input signal to TB1. Make sure that negative, common or low is connected to "C" on TB1.
8. Apply 115 VAC power to the card set. One of the two light should come on. If none of the lights come on, check the following:
  - A. Power is present at TB1 of 7006.
  - B. Power supply fuse open or broken lead.
  - C. That J1 is NOT jumpered.
  - D. Light bulbs are operational.
  - E. Feedback pot is already at 0% position. (This can be checked by rotating the pot gear one turn clockwise or counterclockwise).
  - F. Interconnect wiring for breaks or misconnections.
9. Turn the feedback pot gear clockwise until both lights go out.
10. Remove 115 VAC power first, then remove the input signal.
11. Carefully engage the feedback pot gear to the motor gear and tighten both 6-32 x 1/2" screws. On Series 2000 pumps, care must be taken to maintain equal distance from standoffs to pot gear. (Gear centered between both standoffs.) Actuator and pump are now synchronized. Remove power, feedback pot and test cable connections from both cards.
12. Replace the Zerust vapor capsule. If a new capsule is being used, do not forget to date it. This capsule should be replaced on a yearly basis.
13. Position the power supply card over the three standoffs (3547) oriented with TB2 at approximately the five o'clock position. Be sure all three black fiber washers are in place on the underside of the power supply card and over the mounting holes securing it in place with the three shorter standoffs (3548).
14. Connect the motor leads red, black and white to P1 on the bottom card, feedback pot leads gray, brown and yellow to P2 on the top card, and the phase shift network leads to the red wires on the underside of the bottom card. These wires should be tied back and clear of all moving parts, override shaft area and the conduit entry holes.
15. Reconnect 115 VAC power and signal lines to P.C. Cards. Apply a 4 MADC signal and then

apply 115 VAC power. Place a mark on the override coupling (3409). Inject a 20 MADC signal and count the turns from 4 MADC to 20 MADC. There should be ten turns for Series 900, 1000 and Hydromyte, and twenty turns for Series 2000. Any differences can be adjusted out using the ratio pot R130. Before making the final adjustment to the ratio pot, high limit must be checked. Apply 20 MADC and very carefully adjust the ratio pot clockwise (extremely small adjustments are in order) and note the amount of rotation past one hundred percent. The recommended allowable is one-eighth turn. If the coupling rotates more than one-eighth (1/8) turn past one hundred percent, adjust the ratio pot counterclockwise (decreasing capacity) enough to bring the coupling (3409) one turn counterclockwise from one hundred percent. Adjust the high limit pot (R128) counterclockwise one turn. Readjust the ratio pot (R130) clockwise and check maximum rotation past one hundred percent. Repeat this procedure using small incremental adjustments until the actuator falls within stated operating parameters. After initial adjustment, increments of one half turn or less should be used on "HI" pot (R128). Adjust the ratio pot (R130) for the one hundred percent position. Inject a 4 MADC signal to bring the actuator to zero percent capacity. Remove the input signal altogether and note the amount of rotation below zero. There should be no more than one-eighth (1/8) turn. If more than one-eighth (1/8) turn or jamming occurs, inject 6 MADC and then adjust the low pot (R129) clockwise approximately one half turn. Inject 4 MADC to bring the actuator to zero capacity and then remove the signal altogether and again observe counterclockwise rotation below zero. Repeat this procedure using small incremental adjustments until actuator falls within stated operating parameters. This concludes the resynchronization procedure.

## RETURNING TO SERVICE

1. Reconnect wiring to actuator and pump motor making sure all conduit and hubs are liquid tight. Do not apply power at this time.
2. Connect suction and discharge piping.
3. Adjust oil level as required and replace oil cover.
4. Open any suction and discharge valves and check supply vessel for minimum fluid level.

5. Inject a 4 MADC signal and apply 115 VAC power to the actuator and start the pump motor.
6. Gradually increase input signal to 20 MADC while checking for leaks and correct pump/actuator performance (noisy orientation, overcurrent, jamming, etc.). If pump is installed outdoors in temperatures below 40°F, intermittent actuator stalling may occur. This will not cause any damage or an out of sync condition. To obtain maximum pump/actuator performance, it is recommended that ambient temperatures above 40°F be maintained.
7. Inject a 4 MADC signal to bring the actuator to 0% capacity. Remove power from the pump motor, correct any leaks as necessary and recheck the oil level in the pump (refer to the pump manual for the correct oil grade and level). Be sure all covers are on tight. This is important to maintain NEMA integrity and prevent liquid entry, which may cause damage to the pump and the actuator.
8. Adjust capacity decal (3440) to line up with capacity indicator ring (3412) while the pump is at zero percent capacity position. Replace the scale if it is damaged or hard to read.
9. Pump is ready for service.

## OUTDOOR INSTALLATIONS

Special consideration must be given when the pump and actuator are used in outdoor service. Avoid locating the pump and actuator in an area where flooding or direct water runoff can occur.

Although the pump and actuator are designed for outdoor service, condensation will form within the actuator housing as temperatures fluctuate, especially in sub-tropical or humid environments.

In all outdoor installations, a space heater should be installed in the actuator enclosure, or the unit should be heat traced such that a temperature of 55-70°F can be maintained.

Properly sized space heaters are available from ACUFLOW™. Consult the factory or your local representative for additional information.

# Hook-Up Diagram Electronic Capacity Control (Local)

- TB1 - 4-20maDC Input Signal
- TB2 - 1-60/50-120 Power Input
- TB3 - 4-20maDC/1-5VDC Retransmission

- Notes:
1. Recommended wire size 16 AWG amx.
  2. Input and retransmission signal must be in separate conduit from power input.
  3. Reference board layout drawings -  
Top card - Input buffer/motor logic B-17007  
Bottom card - Power supply/driver B-17006
  4. Conduit connection size - 1/2" - 14 NPT
  5. Remove Plastic Plug and replace with metallic to maintain NMEA enclosure integrity.

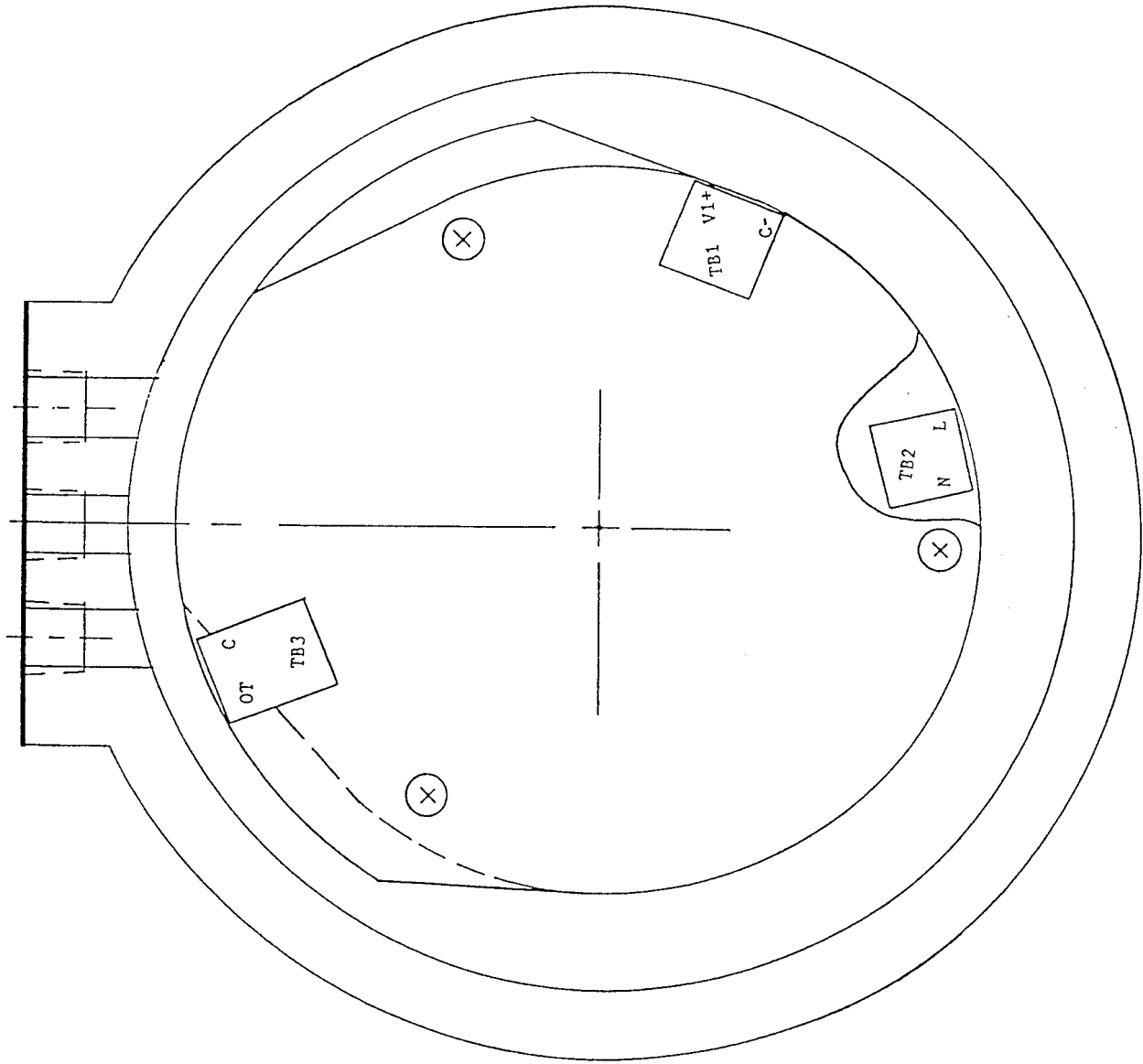

End View

## Board Layout Power Supply/Driver

Des	Description
CA, C5	Capacitor -.01UF 500V
C2	Capacitor Elec. 470UF 80V
C3, C4, C6	Capacitor .1UF 50V
C7	Capacitor .01UF 100V
CR1	Diode Bridge Rectifier 1 AMP 600 PRV
CR2	Diode Zener 13V
CR3	Diode Zener 4.7V
CR4, CR5	Triac 800V @ 8 AMP
F1	Fuse 3 Amp
P1	Plug header 4 position
Q1	Transistor 2N2222A
Q2	Transistor 2N3054
R100, R103	Resistor 30 Ohms 1/2 watt C.C.
R101, R102	Resistor 560 Ohms 1/2 Watt C.C.
R104, R105	Resistor 3.9K Ohms 1/2 Watt C.C.
R106	Resistor 16.5K Ohms 1/4 Watt H.F.
T1	Transformer 120 x 30 100MA
TB2	Terminal Block 2 position right angle
V1	Varistor
U1	Voltage Regulator +24 volt an7824
U2	Voltage Regulator +5 volt ECG 977
U3	Voltage Reference 1.2V LM385Z1.2
U7, U8	Triac driver optoisolator MOC 3083

Top of Actuator

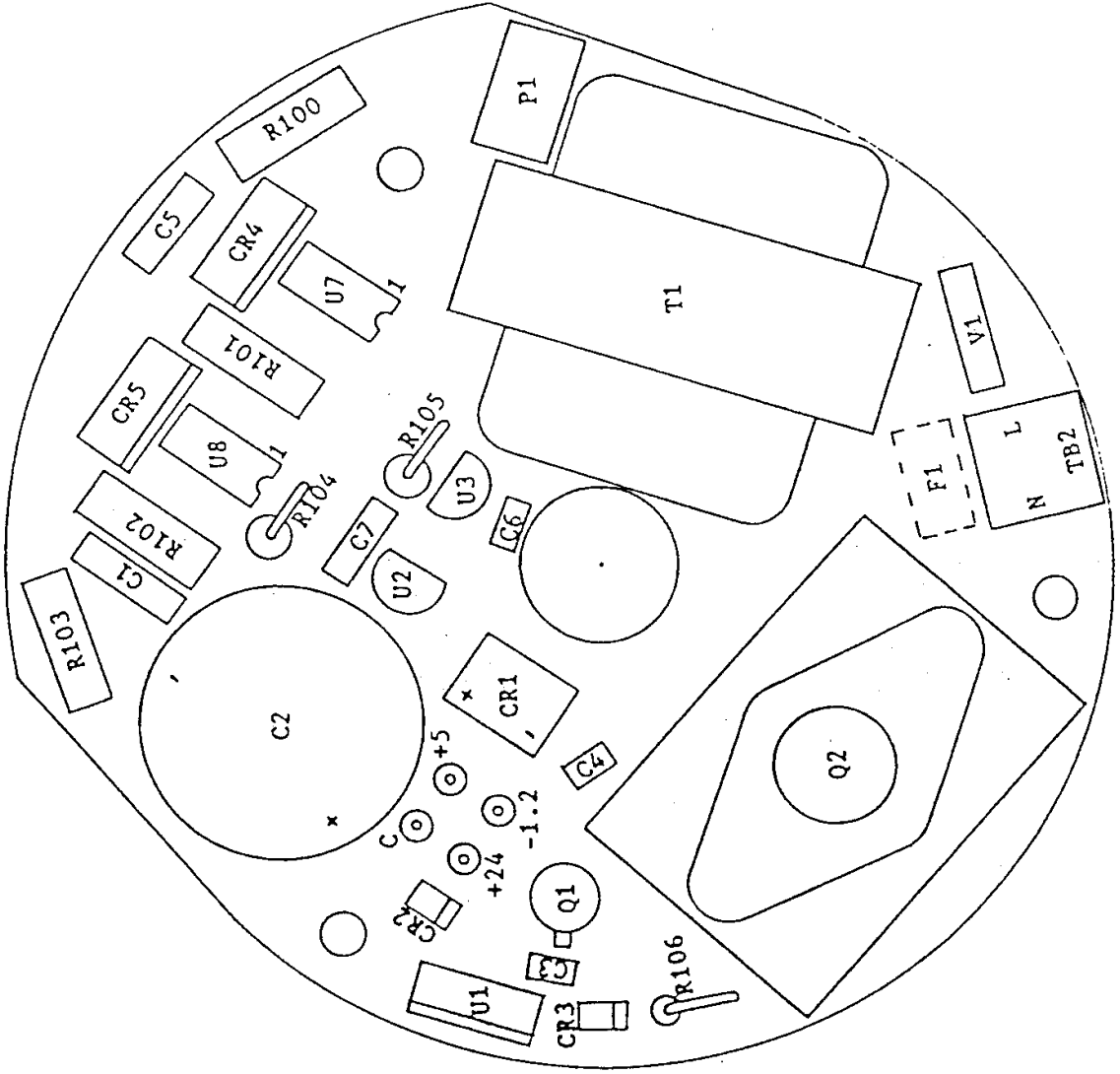

# Board Layout Input Buffer/Motor Logic

Des	Description
C100	Capacitor .01UF 100V Ceramic
C101, 103	Capacitor .1UF 50V Ceramic
C102	Capacitor 10UF 16V TANT
CR1	Diode IN 4003
P2	Jumper Plug Header 4 Position Locking
Q3, Q4	Transistor 2N2222A
Q5	Transistor 2N2484
Q6	Transistor 2N2270
R100, R101	Resistor 5.6K 1/4W C.C. 5%
R102	Resistor 5.76K 1/4W M.F. 1%
R103	Resistor 3.3M 1/4W C.C. 5%
R104	Resistor 249K 1/4W M.F. 1%
R105	Resistor 11K 1/4W M.F. 1%
R106	Resistor 499K 1/4W M.F. 1%
R107	Resistor 453K 1/4W M.F. 1%
R108	Resistor 100K 1/4W M.F. 1%
R109	Resistor 200K 1/4W M.F. 1%
R110, R113	Resistor 17.4K 1/4W M.F. 1%
R111, R112	Resistor 200 OHMS 1/4W M.F. 1%
R114	Resistor 24.9K 1/4W M.F. 1%
R115, R116	Resistor 1M, 1/4W M.F. 1%
R117, R133	Resistor 249 OHM 1/4W M.F. 1%
R118	Resistor 10K OHM 1/4W M.F. 1%
R119, R120	Resistor 20K OHM 1/4W M.F. 1%
R121	Resistor 4.22K OHM 1/4W M.F. 1%
R122	Resistor 46.4K OHM 1/4W M.F. 1%
R123	Resistor 3.01K OHM 1/4W M.F. 1%
R124	Resistor 158K 1/4W M.F. 1%
R125	Resistor 49.9K 1/4W M.F. 1%
R126, R127	Potentiometer 2K 1/2W Multi-turn
R128, R129	Potentiometer 10K 1/2W Multi-turn
R130	Potentiometer 100K 1/2W Single Turn
R131, R132	Potentiometer 5K 1/2W Multi-turn
RN1	Resistor network 3.9K OHM
RN2, RN3	Resistor Network 10K OHM
TB1, TB3	Terminal block 2 position right angle
TP2	Turret terminal
U4	I.C. LH324N
U5	I.C. LH339N
U6	I.C. CD4082BCN
U7	I.C. LH358N
J1	Jumper, shorting

Top of Actuator

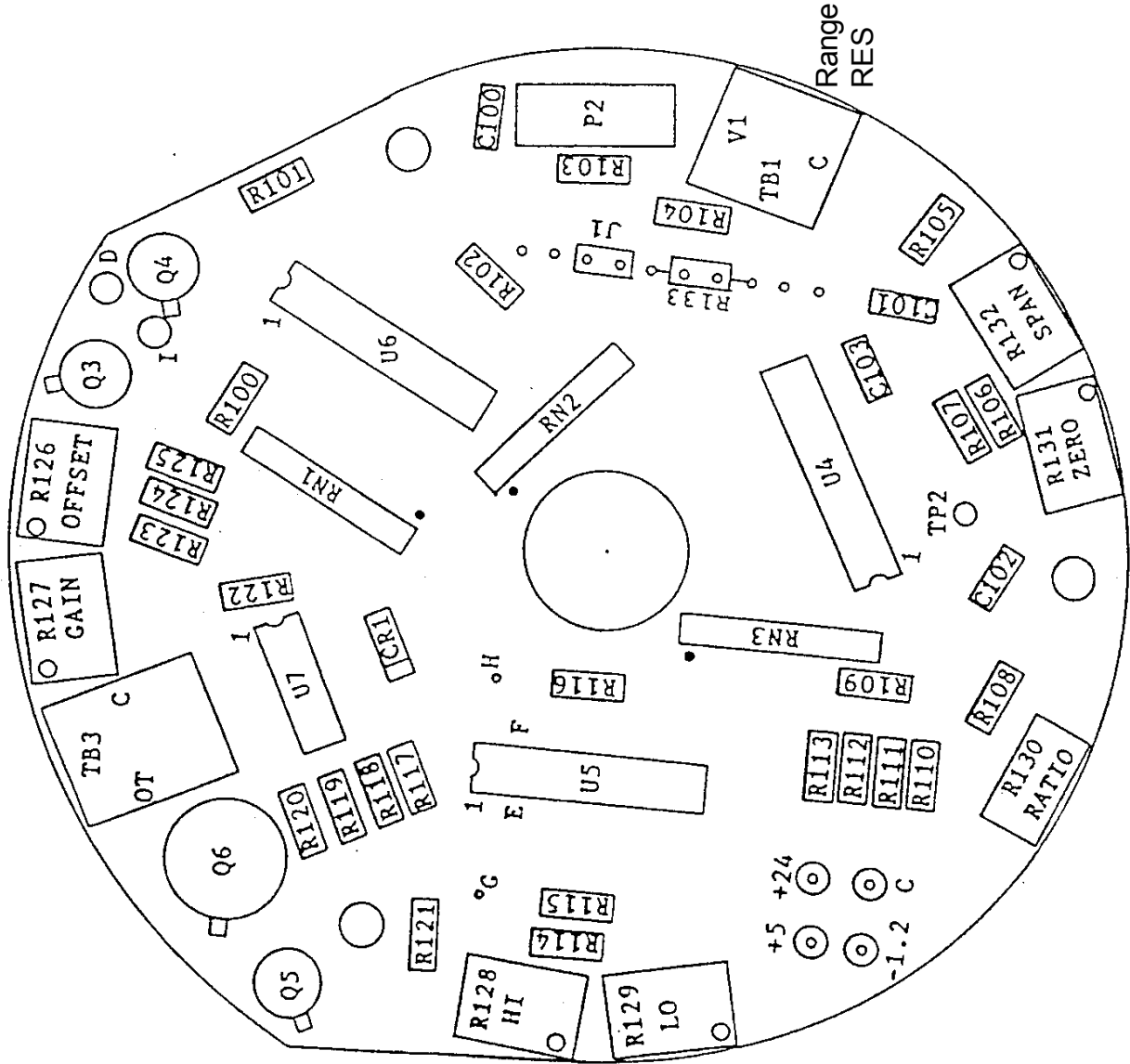





# Electrical Schematic Power Supply & Drive Card

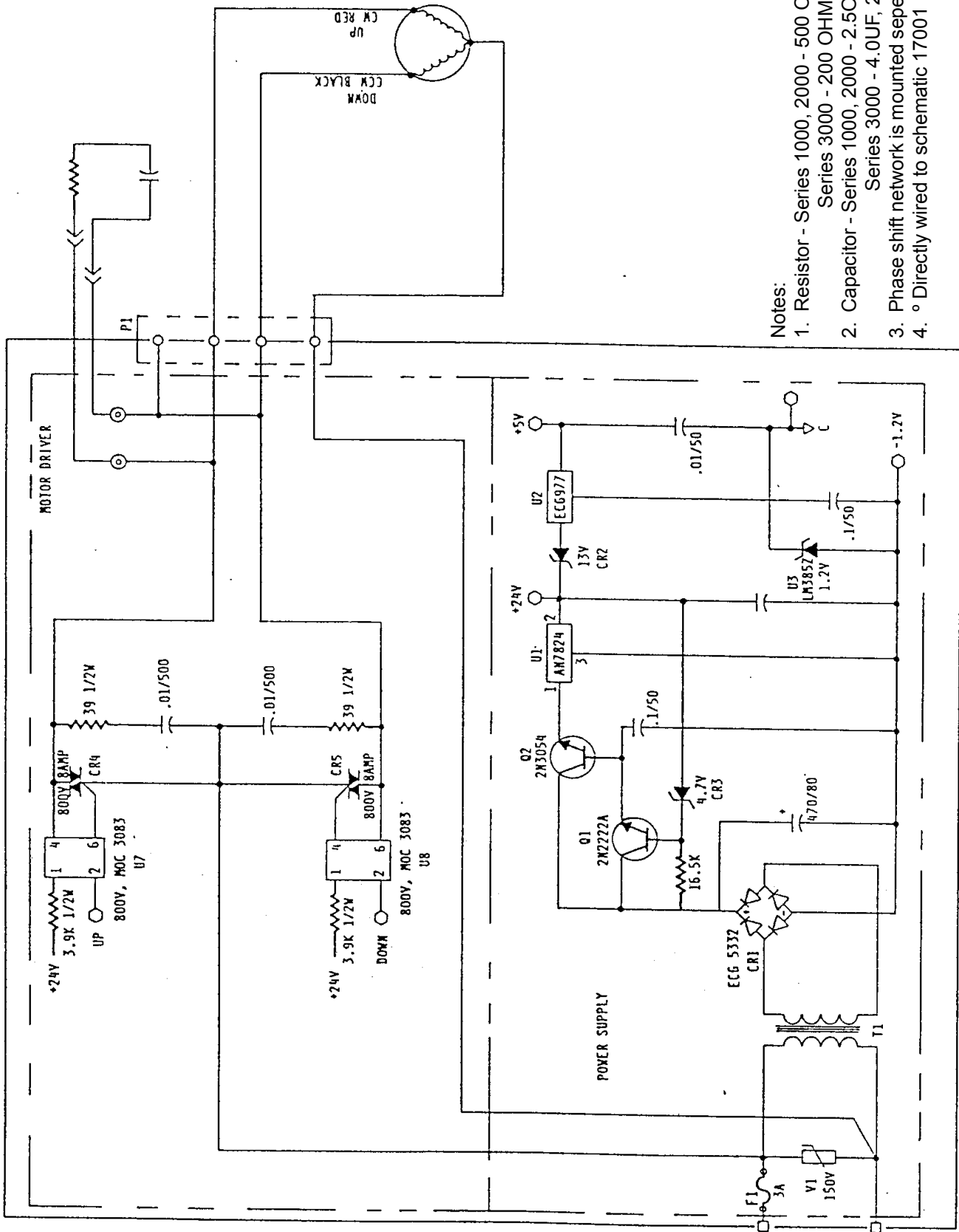

- Notes:
1. Resistor - Series 1000, 2000 - 500 OHMS, 25 Watts  
Series 3000 - 200 OHMS, 25 Watts
  2. Capacitor - Series 1000, 2000 - 2.5OUF, 280 VAC  
Series 3000 - 4.0UF, 280VAC
  3. Phase shift network is mounted separate from P.C. Card
  4. ° Directly wired to schematic 17001

Item	Qty	Description
1	1	4 Pin Connector
2	1	4 Pin Dust Cover
3	12"	22 AWG Black
4	12"	22 AWG Red
5	12"	22 AWG White

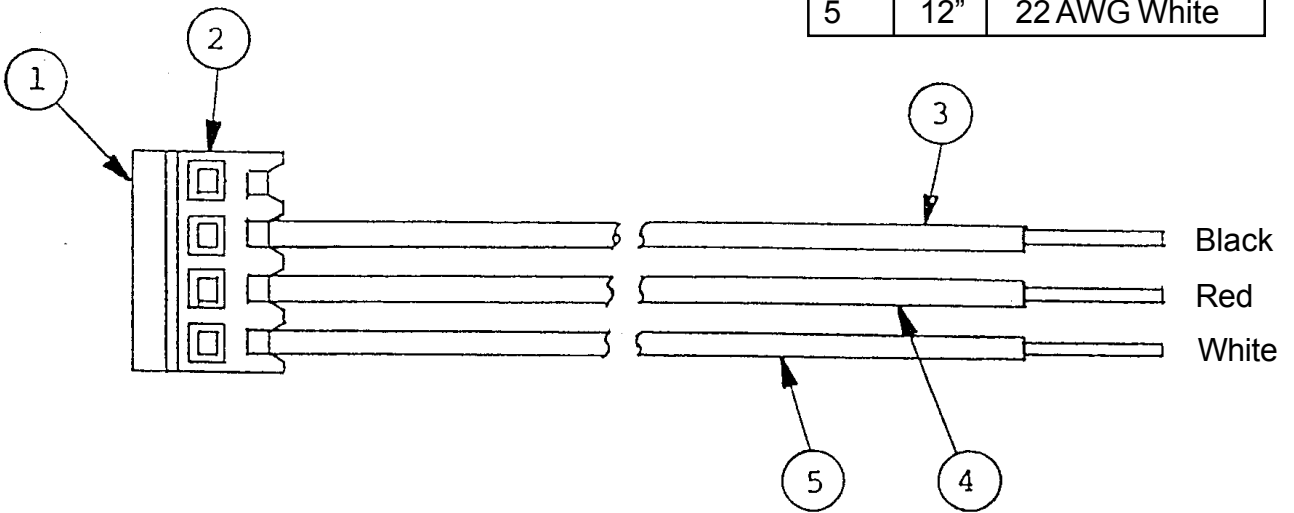

Test Cable - Synchronization  
Local Control

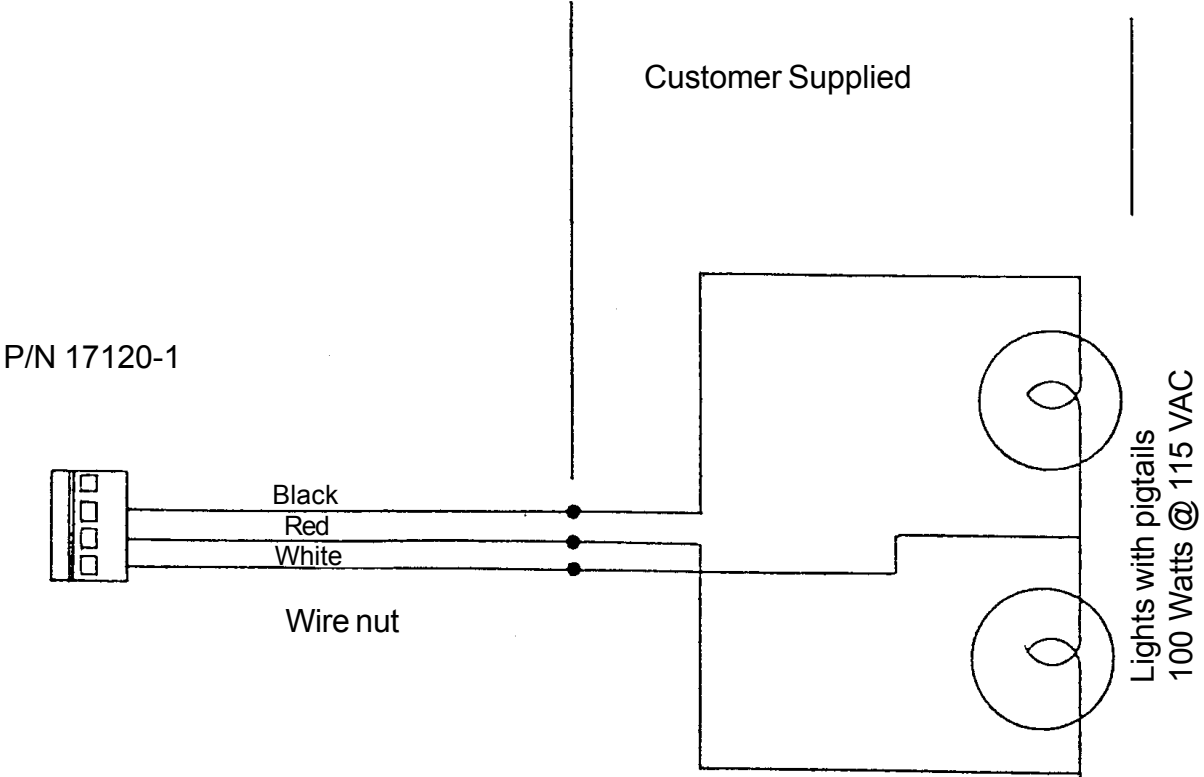

Test Cable Hook-up Schematic

# Series 1000/2000 Motor Coupling Installation

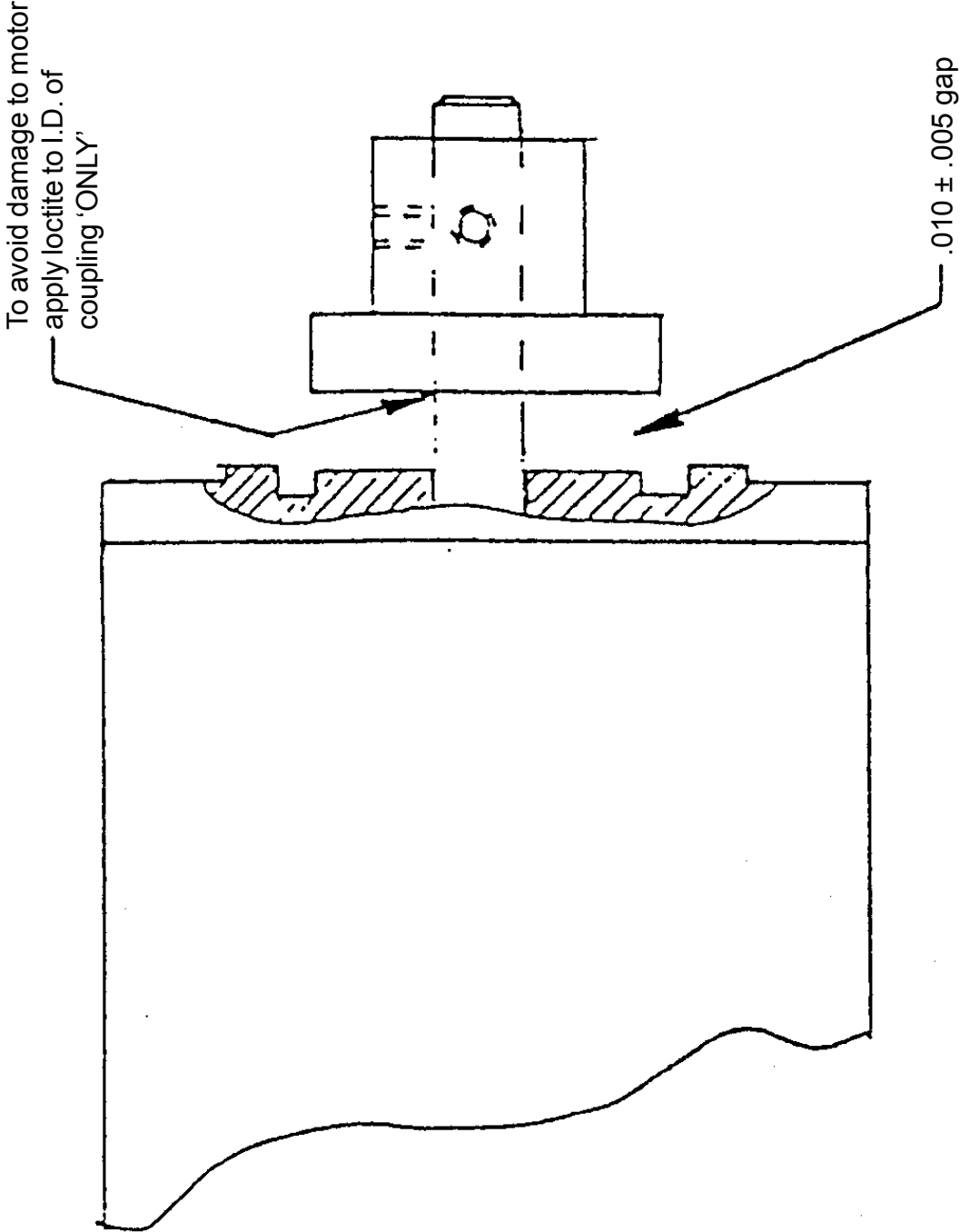

# Electronic Capacity Control Actuator

## Cross Section & Parts List - Series 1000, all plungers

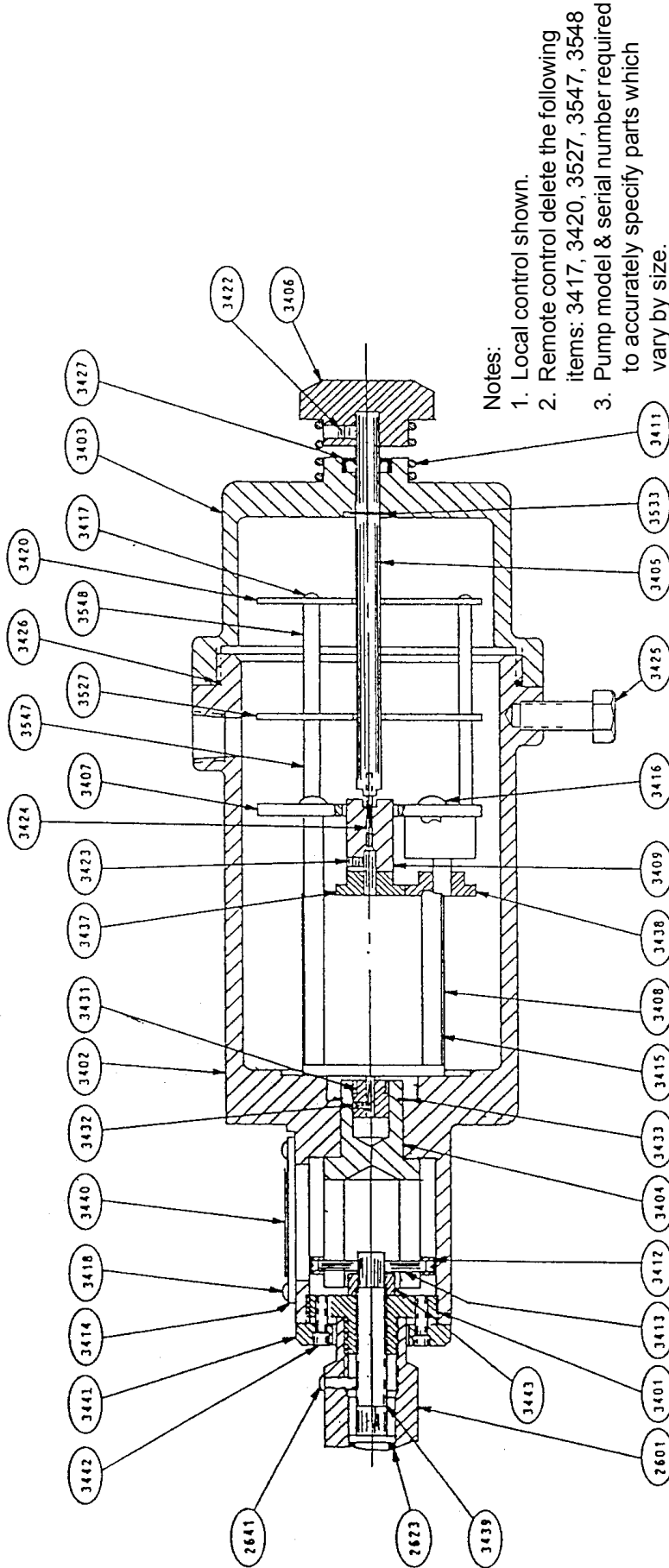

**Notes:**

1. Local control shown.
2. Remote control delete the following items: 3417, 3420, 3527, 3547, 3548
3. Pump model & serial number required to accurately specify parts which vary by size.
4. All information contained herein subject to change without notice.

Item	Qty	Description	Item	Qty	Description	Item	Qty	Description
2601	Ref	Housing Pump	3413	1	Pin, indicator	3431	1	Coupling, motor
2623	Ref	O-ring, control spool assembly	3414	1	Plate, capacity	3432	2	Set screw, coupling
2641	Ref	Screw, control spool	3415	4	Standoff, motor plate	3433	1	Snap ring, actuator
3401	1	Adapter, housing	3416	4	Screw, motor plate	3437	1	Gear, motor
3402	1	Housing	3417	3	Screw, PC board	3439	1	Control spool assembly
3403	1	Cover, housing	3418	4	Screw, capacity plate	3440	1	Decal, capacity
3404	1	Actuator	3420	1	PC board assy. input buffer/motor logic. retransmission	3527	1	PC board assy., power supply/driver
3405	1	Shaft, override	3422	Ref	Set screw, knob	3533	1	Snap ring
3406	1	Knob, override	3423	2	Set screw, coupling	3547	3	Standoff, PC board
3407	1	Plate, motor	3424	1	Pin, override	3548	3	Standoff, PC board
3408	1	Motor	3425	A/R	Bolt	3441	1	Clamp ring
3409	1	Coupling	3426	1	O-ring, housing	3442	4	Screw, clamp ring
3411	1	Spring, override	3427	1	Seal, shaft override	3443	1	Stop collar
3412	1	Indicator, capacity						
			3424			3425		
			3407			3416		
			3423			3409		
			3437			3438		
			3431			3408		
			3402			3415		
			3432			3433		
			3440			3404		
			3418			3412		
			3414			3413		
			3441			3401		
			3426			3443		
			3547					
			3527					
			3424					
			3407					
			3548					
			3426					
			3420					
			3417					
			3403					
			3411					
			3406					
			3422					

# Electronic Capacity Actuator

## Cross Section & Parts List - Series 2000 all plungers

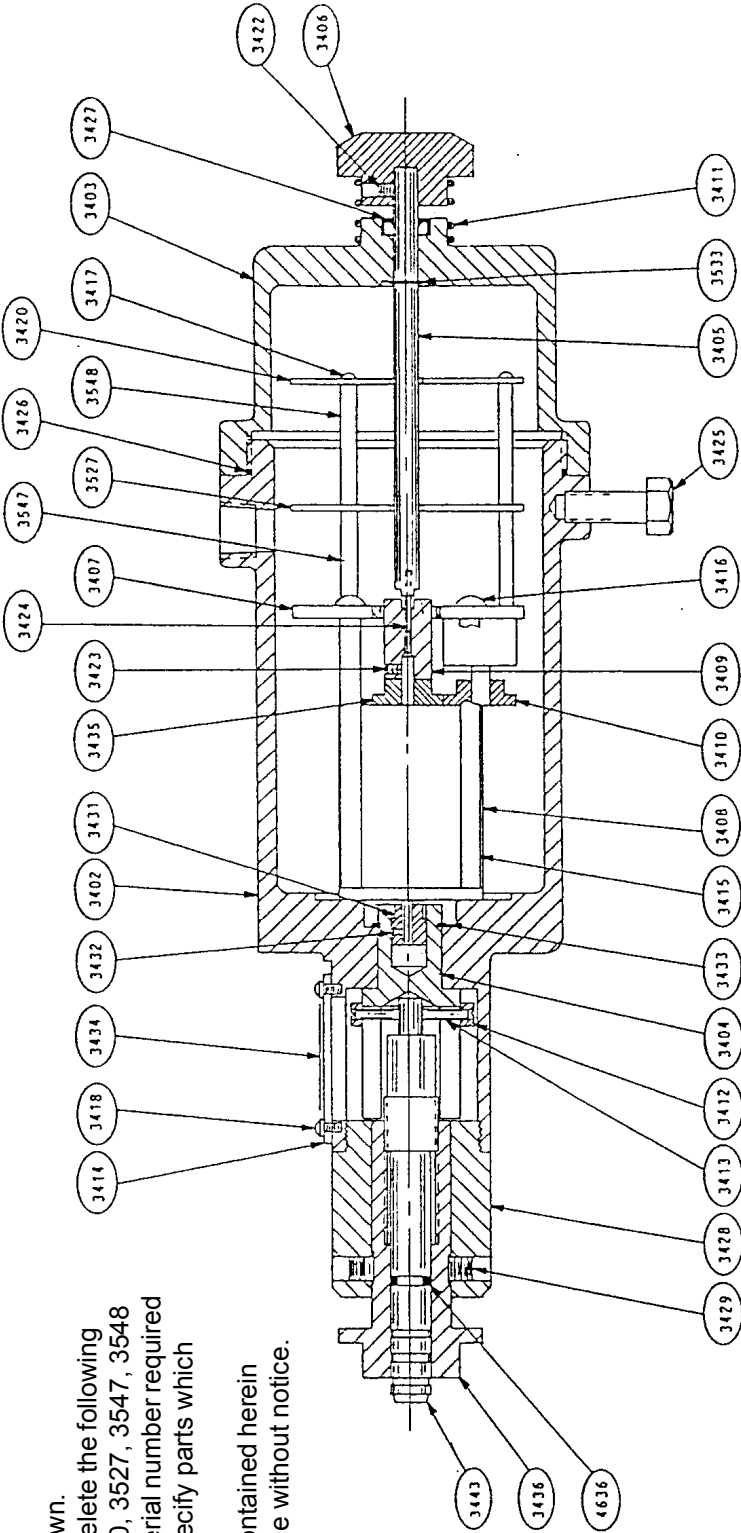

- Notes:
1. Local control shown.
  2. Remote control delete the following items: 3417, 3420, 3527, 3547, 3548
  3. Pump model & serial number required to accurately specify parts which vary by size.
  4. All information contained herein subject to change without notice.

Item	Qty	Description	Item	Qty	Description	Item	Qty	Description
3402	1	Housing	3416	4	Screw, motor plate	3431	1	Coupling, motor
3403	1	Cover, housing	3417	3	Screw, PC board	3432	2	Set screw, coupling
3404	1	Actuator	3418	4	Screw, capacity plate	3433	1	Snap ring, actuator
3405	1	Shaft, override	3420	1	PC board assy. input buffer/motor logic. retransmission	3434	1	Decal, capacity
3406	1	Knob, override	3422	Ref	Set screw, knob	3435	1	Gear, motor
3407	1	Plate, motor	3423	2	Set screw, coupling	3527	1	PC Board assy., power supply/driver
3408	1	Motor	3424	1	Pin, override	3533	1	Snap ring
3409	1	Coupling	3425	A/R	Bolt	3547	3	Standoff, PC board
3410	1	Ger, potentiometer	3426	1	O-ring, housing	3548	3	Standoff, PC board
3411	1	Spring, override	3427	1	Seal, shaft override	3436	1	Adjuster housing
3412	1	Indicator, capacity	3428	1	Seal, shaft override	3443	1	Adjuster
3413	1	Pin, indicator	3429	2	Set screw, adapter housing	4636	1	O-ring, adjuster
3414	1	Plate, capacity						
3415	4	Standoff, motor plate						

## TROUBLESHOOTING SEQUENCE

SYMPTOM	PROBABLE CAUSES	RECOMMENDED ACTION
<p>1. Actuator does not respond to input.</p> <div style="border: 1px solid black; padding: 5px; margin-top: 10px;"> <p><b>Note:</b> The two red wires on the underside of the power supply connect to the phase shift network. Disconnect these leads at the wires for access to the network connectors.</p> </div>	<p>Power not present at control cards.</p> <p>Process signal (4-20 MADC/ 1-5 VDC) not present at TB1.</p> <p>Process signal connected to signal output instead of signal input.</p> <p>Phase shift network not connected or defective.</p>	<p>Check for power at TB2 "N" and "L" for 115 VAC.</p> <p>Check for correct signal at TB1 on top card 17007. Connect dvm across "C" and "V1" at controller. Actuator responds to 4-20 MADC signal which is converted to 1-5 VDC at TB1.</p> <p>Check input/output connections. Refer to hookup diagram.</p> <p>Check phase shift network connections on underside of power supply card.</p> <p>Check phase shift network for shorted or open components. Set OHM meter to Rx10K scale. Needle deflection should rise to approximately 1/2 scale and return to 1000K OHMS. If meter does not return to 1000K OHMS or does not move at all, phase shift network is defective.</p>
<p>2. Actuator power supply fuse F-1 clears after application of power.</p>	<p>Shorted motor, phase shift network or power supply transformer.</p>	<p>Remove connector from P1 and check resistance between RED and BLACK wire. Reading should be approximately 450-500 ohms; across black or red to white 225-250 ohms, and 1000k ohms from any three to the frame. If motor is shorted, contact ACUFLOW™ for a replacement motor.</p> <p>Check both phase shift network leads for a short circuit to ground (Casing).</p> <p>Check power supply transformer for a shorted or open primary/secondary. Resistance at the primary should be approximately 300 ohms and at the secondary 50 ohms. If the transformer is shorted or open replace entire card set. Call ACUFLOW™ for replacement parts.</p>
<p>3. Actuator exhibits poor response and controls only half the output of the pump.</p>	<p>Plus and minus process signal wires are switched.</p>	<p><b>CHECK CONNECTIONS!</b> Minus (com, lo-), side of process MUST be connected to terminal "C" of TB1, high side to terminal V1.</p>
<p>4. Manual override feature is hard to turn or "feels rough". Does not stay positioned.</p>	<p>Power still applied to actuator.</p>	<p>Remove power to actuator. or Disable actuator motor via J1. See page 5, section3, under "SIGNAL INPUTS".</p>
<p>5. Pump does not respond to manual override or the automatic positioner. (Positioner turns but actuator coupling 3404 does not). Series 900, 1000, 2000 and Hydromyte.</p>	<p>Drive coupling loose or broken.</p>	<p>Tighten or replace drive coupling. See page ___ under 'REMOVAL OF SYNCHRONOUS MOTOR'.</p>

## Replacement Part Numbers

Item	Description	Part No.	Direct Drive Series
3401	adapter, housing	17093-1	1000
3402	actuator housing	17083-1	all
3403	cover housing	17086-1	all
3404	actuator	17103-1	all
3405	shaft, override	17074-1	all
3406	knob, override	17065-0001	all
3407	plate motor	17071-1	all
	capacitor 2.5Mf	17014-0401	all
	resistor 500 ohm	17021-0103	all
	pot bracket	17088-1	all
	potentiometer 5k with cable	17123-1	all
	screw, rh (4-40 x 1/4")	07430-2104	all
	screw, rh (6-32 x 1/2")	07430-2208	all
	terminal qd f	02F6-18279	all
	terminal qd m	02F8-18278	all
	vapor capsules	17111-1	all
3408	motor, ac syn 90 oz/in	17109-1	all
	motor cable assembly	17122	all
3409	coupling	17087-1	all
3410	gear potentiometer	17097-1004	2000
3411	spring, override	17070-1	all
3412	capacity indicator	17090-1	all
3413	drive pin, indicator	17102-1	1000
	drive pin, indicator	07750-41528	2000
3414	plate capacity	17092-1	all
3415	standoff	17042-1	all
3416	screw, motor plate (10-32 x 1/2")	07460-2408	all
3417	screw, pcb (6-32 x 3/8")	07430-2206	all
3418	screw, capacity plate (8-32 x 3/8")	07410-3306	all
3420	pcb set, power supply/input buffer	17108-1	all
3422	set screw knob (10-32 x 3/8")	07310-4406	all
3423	set screw, coupling (8-32 x 1/4")	07310-4304	all
3424	pin override	12530-0207	all
3425	stud	a/r	all
3426	o-ring housing	12020-1125	all
3427	seal, shaft override	15036-1005	all
3428	adapter, housing	17091-1	2000
3429	set screw (3/8-16 x 1/2")	07310-4908	2000
3431	coupling motor	17104-1	all
3432	set screws motor (8-32 x 3/16")	07310-4303	all
3433	snap ring, actuator	07900-4100	all
3434	decal capacity scale	12135-0	2000
3435	gear motor	17091-1001	2000
3437	gear, motor	17097-1002	1000
3438	gera, potentiometer	17097-1003	1000
3440	decal capacity scale	12544-0	1000
3441	clamp ring	17049-1	1000
3442	screw, clamp ring (10-32 x 1/2")	07100-4408	1000
3533	snap ring	17075-1101	all
3547	standoff 2"	17024-31250	all
	washer #8 fiber, non-metallic	07800-10200	all
3548	standoff 1-1/2"	17024-31203	all

## PARTS ORDERING INSTRUCTIONS

Always have the complete ACUFLOW™ pump model and serial number available when contacting ACUFLOW for parts or service. This information can be found on the nameplate mounted on the side of the pump.

Because of the complicated solid-state circuitry contained in the control unit, we do not recommend field servicing unless the necessary tools and test equipment are available.

Should it be necessary to send the pump and electric capacity control to the factory for repair or service, thoroughly flush the pump liquid end of all process fluid, drain all hydraulic oil, pack securely for shipment, and call factory for a return authorization number. A material safety data sheet (MSDS) and a signed Return Goods Authorization form will be required. Equipment received without return authorization number will not be accepted.

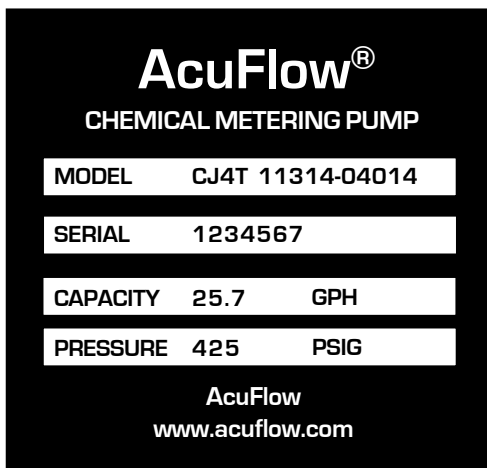

Direct all inquiries and orders to your local representative or directly to:

**AcuFlow**

1642 McGaw Ave

Irvine, CA 92614

Telephone: (949) 757-1753

Fax: (949) 757-1687

Website: [www.acuflow.com](http://www.acuflow.com)

E-mail: [sales@acuflow.com](mailto:sales@acuflow.com)